

**RoamAbout®**

Wireless Networking

---

**RBT-4102 / RBT-1602 Wireless Access Point**

Antenna Site Preparation and Installation Guide





**Electrical Hazard:** Only qualified personnel should perform installation procedures.

**Riesgo Electrico:** Solamente personal calificado debe realizar procedimientos de instalacion.

**Elektrischer Gefahrenhinweis:** Installationen sollten nur durch ausgebildetes und qualifiziertes Personal vorgenommen werden.

## Notice

Enterasys Networks reserves the right to make changes in specifications and other information contained in this document and its web site without prior notice. The reader should in all cases consult Enterasys Networks to determine whether any such changes have been made.

The hardware, firmware, or software described in this document is subject to change without notice.

IN NO EVENT SHALL ENTERASYS NETWORKS BE LIABLE FOR ANY INCIDENTAL, INDIRECT, SPECIAL, OR CONSEQUENTIAL DAMAGES WHATSOEVER (INCLUDING BUT NOT LIMITED TO LOST PROFITS) ARISING OUT OF OR RELATED TO THIS DOCUMENT, WEB SITE, OR THE INFORMATION CONTAINED IN THEM, EVEN IF ENTERASYS NETWORKS HAS BEEN ADVISED OF, KNEW OF, OR SHOULD HAVE KNOWN OF, THE POSSIBILITY OF SUCH DAMAGES.

Enterasys Networks, Inc.  
50 Minuteman Road  
Andover, MA 01810

© 2006 Enterasys Networks, Inc. All rights reserved.

Part Number: 9034254 May 2006

ENTERASYS, ENTERASYS NETWORKS, ROAMABOUT, and any logos associated therewith, are trademarks or registered trademarks of Enterasys Networks, Inc., in the United States and other countries.

All other product names mentioned in this manual may be trademarks or registered trademarks of their respective companies.

**Documentation URL:** <http://www.enterasys.com/support/manuals>

**Documentacion URL:** <http://www.enterasys.com/support/manuals>

**Dokumentation URL:** <http://www.enterasys.com/support/manuals>



---

# Contents

## About This Guide

Intended Audience .....	vii
Related Documents .....	viii
Getting Help .....	viii
Conventions Used in This Guide .....	ix

## Chapter 1: Site Preparation

Choosing Antennas for Wireless Network Configurations .....	1-2
Determining the Antenna Locations .....	1-3
Distances with Cables .....	1-3
Line of Sight .....	1-5
Other Factors That Can Reduce Antenna Range .....	1-7
Additional Location Requirements .....	1-8
Antenna Models .....	1-9
Cable Options .....	1-11
Lightning Protector .....	1-11
RoamAbout Pigtail Connection Options .....	1-12
Contacting an Antenna Installation Company .....	1-13
Lightning Protection .....	1-13
Mounting Requirements .....	1-13
Line of Sight .....	1-13
Installation Requirements .....	1-14

## Chapter 2: AP Placement and Configuration

Determining the Location of the AP .....	2-1
Overview of Connecting Cables to the Access Point .....	2-2
RBT-4102 .....	2-2
RBT-1602 .....	2-4

## Chapter 3: Antenna Installation

Installation Overview .....	3-2
Grounding System .....	3-3
Lightning Protector Installation .....	3-4
Mounting the Antenna .....	3-6
Selecting a Mast .....	3-6
Antenna Polarization .....	3-7
Mounting RoamAbout 2.4 GHz 8 dBi Omni-Directional Base Station Antenna .....	3-8
Mounting the RoamAbout 2.4 GHz Directional Antenna .....	3-10
Mounting on a Wide Mast .....	3-10
Mounting On a Narrow Mast .....	3-12
Mounting the RoamAbout 2.4 GHz Sector Panel Antenna .....	3-14
Mounting the RoamAbout 2.4 GHz 6 dBi 180 Degree Sector Panel Antenna (RBT-1602 only) .....	3-16
Pole Installation .....	3-18
Solid Wall Installation .....	3-18
Mounting the RoamAbout 2.4 GHz 7 dBi 120 Degree Sector Panel Antenna .....	3-19
Mounting the RoamAbout 2.4 GHz 10 dBi 60 Degree Sector Panel Antenna .....	3-19
Mounting the RoamAbout 5.1-5.9 GHz 10.8 dBi 180 Degree Sector Panel Antenna .....	3-19
Mounting the RoamAbout 5.1-5.9 GHz 14.5 dBi 60 Degree Sector Panel Antenna .....	3-19
Mounting the RoamAbout 5.1-5.9 GHz 12.5 dBi 120 Degree Sector Panel Antenna .....	3-19

Mounting the RoamAbout 5.3 and 5.8 GHz Omni-Directional Antennas .....	3-19
Mounting On a Mast .....	3-20
Mounting On a Wall .....	3-21
Mounting the RoamAbout 5.8 GHz Panel Antenna .....	3-22
Mounting the Antenna to a Wall .....	3-22
Mounting the Antenna to a Mast.....	3-25
Mounting the RoamAbout 4.9 to 5.9 GHz Sector Panel Antennas .....	3-29
Mounting the 802.11a/b/g Range Extender (Omni-Directional) Antenna .....	3-32
Using the Ceiling Mount .....	3-32
Connecting the Antenna Cables .....	3-34
Using the Female Pigtail .....	3-34
Using The Male Pigtail .....	3-35
Antenna Cable Route .....	3-36
Connecting the Cables .....	3-36
Optimizing RoamAbout Outdoor Point-to-Point Antenna Placement .....	3-37
Routine Maintenance .....	3-37

## Appendix A: Specifications

RoamAbout 2.4 GHz 8 dBi Omni-Directional Base Station Antenna .....	A-2
RoamAbout 2.4 GHz Directional Panel Antenna .....	A-3
RoamAbout 2.4 GHz Sector Panel Antenna .....	A-4
RoamAbout 2.4 GHz 6 dBi 180 Degree Sector Panel Antenna .....	A-5
RoamAbout 2.4 GHz 7 dBi 120 Degree Sector Panel Antenna .....	A-6
RoamAbout 2.4 GHz 10 dBi 60 Degree Sector Panel Antenna .....	A-7
RoamAbout 5.1-5.9 GHz 10.8 dBi 180 Degree Sector Panel Antenna .....	A-8
RoamAbout 5.1-5.9 GHz 12.5 dBi 120 Degree Sector Panel Antenna .....	A-9
RoamAbout 5.1-5.9 GHz 14.5 dBi 60 Degree Sector Panel Antenna .....	A-10
RoamAbout 5.3 GHz 10db Omni-Directional Antenna .....	A-11
RoamAbout 5.8 GHz 10 dBi Omni-Directional Antenna .....	A-12
RoamAbout 5.8 GHz Panel Antenna .....	A-13
RoamAbout 4.9 to 5.9 GHz Sector Panel Antenna .....	A-15
802.11a/b/g Range Extender Omni-Directional Antenna .....	A-16
RoamAbout Pigtail Connection .....	A-17
Low-Loss Antenna Cable .....	A-18
RoamAbout Lightning Protector .....	A-21

## Figures

1-1 Fresnel Zone and Line of Sight Clearance .....	1-5
1-2 Potential Obstacles to Line of Sight (not to scale).....	1-6
1-3 Large Reflecting Surfaces .....	1-7
2-1 RBT-4102 Installation Overview .....	2-2
2-2 RBT-1602 Installation Overview .....	2-4
3-1 Lightning Protector Installation .....	3-4
3-2 Mounting the 2.4 GHz Omni-Directional Antenna to a Mast.....	3-8
3-3 Mounting the RoamAbout 2.4 GHz Directional Antenna on a Wide Mast .....	3-10
3-4 Mounting the RoamAbout 2.4 GHz Directional Antenna on a Narrow Mast.....	3-12
3-5 Mounting Sector Panel Antenna - Wide Mast.....	3-14
3-6 Mounting Sector Panel Antenna - Narrow Mast .....	3-15
3-7 RBT-1602 Antennas .....	3-17
3-8 Mounting 2.4 GHz 6 dBi Sector Panel Antenna .....	3-17
3-9 Mast Mounting the 5.3 and 5.8 GHz Omni-Directional Antenna.....	3-20
3-10 Wall Mounting the 5.3 and 5.8 GHz Omni-Directional Antenna .....	3-21
3-11 Attaching Antenna Bracket to RoamAbout 5.8 GHz Panel Antenna .....	3-23
3-12 Mounting the RoamAbout 5.8 GHz Panel Antenna to a Wall .....	3-24
3-13 RoamAbout 5.8 GHz Panel Antenna Mast Mounting Configuration .....	3-25

3-14	Attaching the 5.8 GHz Panel Antenna Bracket to the Antenna .....	3-27
3-15	Mounting RoamAbout 4.9 to 5.9 GHz Sector Panel Antenna — Wide Mast .....	3-29
3-16	Mounting RoamAbout 4.9 to 5.9 GHz Sector Panel Antenna—Narrow Mast .....	3-30
3-17	Installing External Flaps for 4.9 to 5.9 GHz Sector Panel Antenna .....	3-31
3-18	Mounting the 802.11a/b/g Range Extender Antenna to the Ceiling .....	3-32
3-19	Female Pigtail Cable With Lightning Protector .....	3-34
3-20	Female Pigtail Cable Without Lightning Protector .....	3-34
3-21	Male Pigtail Cable With Lightning Protector .....	3-35
3-22	Male Pigtail Cable Without Lightning Protector .....	3-35

## Tables

1-1	Antennas for Wireless Network Configurations .....	1-2
1-2	Outdoor Distance Matrix Between Antennas (RBT-4102 LAN to LAN/MultiPoint) .....	1-3
1-3	RBT-4102 Indoor/Outdoor Antenna Options .....	1-9
1-4	RBT-4102 Indoor Only Antenna Option .....	1-9
1-5	RBT-1602 Indoor/Outdoor Antenna Options .....	1-10
1-6	Cable Options and Model Numbers .....	1-11
1-7	Lightning Protector .....	1-11
1-8	Pigtail Options .....	1-12
2-1	RBT-4102 to Antenna Installation Components .....	2-3
2-2	RBT-4102 Installation Components .....	2-3
2-3	RBT-1602 to Antenna Installation Components .....	2-4
2-4	RBT-1602 Installation Components .....	2-5
3-1	Lightning Protector Mounting Components .....	3-4
3-2	RoamAbout Antennas Mast Diameters .....	3-6
3-3	RoamAbout Omni-Directional Base Station Antenna Mounting Components .....	3-8
3-4	RoamAbout 2.4 GHz Directional Antenna Wide Mast Mounting Component .....	3-10
3-5	RoamAbout 2.4 GHz Directional Antenna Narrow Mast Mounting Components .....	3-12
3-6	RoamAbout 2.4 GHz Sector Panel Mast Mounting Components .....	3-15
3-7	RoamAbout 2.4 GHz 6 dBi Sector Panel Mast Mounting Components .....	3-17
3-8	5.3 and 5.8 GHz Omni-Directional Antenna Mast Mounting Components .....	3-20
3-9	5.3 and 5.8 GHz Omni-Directional Antenna Wall Mounting Components .....	3-21
3-10	RoamAbout 5.8 GHz Panel Antenna Bracket Mounting Components .....	3-23
3-11	RoamAbout 5.8 GHz Panel Antenna Wall Mounting Components .....	3-24
3-12	5.8 GHz Panel Antenna Bracket to Antenna Components .....	3-27
3-13	RoamAbout 4.9 to 5.9 GHz Sector Panel Mast Mounting Components .....	3-30
3-14	RoamAbout 4.9 to 5.9 GHz Sector Panel External Flaps Components .....	3-31
3-15	802.11a/b/g Range Extender Antenna Ceiling Mount Components .....	3-32
3-16	Female Pigtail Cable Configuration Components .....	3-34
3-17	Male Pigtail Cable Components .....	3-35
A-1	2.4 GHz Omni-Directional Antenna Specifications .....	A-2
A-2	RoamAbout 2.4 GHz Directional Panel Antenna Specifications .....	A-3
A-3	RoamAbout 2.4 GHz Directional Panel Antenna Specifications .....	A-4
A-4	RoamAbout 2.4 GHz 6 dBi Directional Panel Antenna Specifications .....	A-5
A-5	RoamAbout 2.4 GHz 7 dBi Directional Panel Antenna Specifications .....	A-6
A-6	RoamAbout 2.4 GHz 10 dBi Directional Panel Antenna Specifications .....	A-7
A-7	RoamAbout 5.1-5.9 GHz 10.8 dBi Sector Panel Antenna Specifications .....	A-8
A-8	RoamAbout 5.1-5.9 GHz 12.5 dBi Sector Panel Antenna Specifications .....	A-9
A-9	RoamAbout 5.1-5.9 GHz 14.5 dBi Sector Panel Antenna Specifications .....	A-10
A-10	5.3 GHz Omni-Directional Antenna Specifications .....	A-11
A-11	5.8 GHz Omni-Directional Antenna Specifications .....	A-12
A-12	RoamAbout 5.8 GHz Panel Antenna Specifications .....	A-13
A-13	RoamAbout 4.9 to 5.9 GHz Sector Panel Antenna Specifications .....	A-15

A-14	802.11a/b/g Range Extender Omni-Directional Antenna Specifications .....	A-16
A-15	Pigtail Connection Specification .....	A-17
A-16	RBTES-L200 Cable Specification.....	A-18
A-17	RBTES-L400 Cable Specifications.....	A-19
A-18	RBTES-L600 Cable Specifications.....	A-20
A-19	Lightning Protector Specifications .....	A-21



---

# About This Guide

This guide describes the requirements for the successful installation of the RoamAbout indoor and outdoor antennas used in a RoamAbout wireless network. A RoamAbout wireless network consists of RoamAbout wireless products that use an 802.11 a/b/g compliant radio.



**Electrical Hazard:** Only qualified personnel should perform installation procedures.

**Riesgo Eléctrico:** Solamente personal calificado debe realizar procedimientos de instalacion.

**Elektrischer Gefahrenhinweis:** Installationen sollten nur durch ausgebildetes und qualifiziertes Personal vorgenommen werden.

## Intended Audience

The RoamAbout outdoor antennas must be installed by an antenna installation professional who can determine, provide, and install the necessary support structure and grounding system. The antenna installation professional should be licensed or certified in accordance with local regulations.

[Chapter 1](#) contains information for a sales engineer or site evaluator to determine the type of outdoor equipment needed to satisfy the customer's outdoor wireless requirements.

[Chapter 2](#) provides information for an antenna installation professional and network manager to determine where to place the RoamAbout AP and Lightning Protector. This chapter also provides an overview of the cabling for the Access Point.

[Chapter 3](#) contains the information needed for an antenna installation professional to set up, install, and test the RoamAbout antennas and cables.

[Appendix A](#) provides the antenna specifications.

## Related Documents

The documentation, drivers, and utilities can also be downloaded from the RoamAbout Wireless web site.

Check the RoamAbout Wireless web site regularly for product upgrades.

<http://www.enterasys.com/products/wireless/>

## Getting Help

For additional support related to the antennas, or this document, contact Enterasys Networks using one of the following methods:

---

World Wide Web	<a href="http://www.enterasys.com/services/support/">http://www.enterasys.com/services/support/</a>
Phone	1-800-872-8440 (toll-free in U.S. and Canada) or 1-978-684-1000 For the Enterasys Networks Support toll-free number in your country: <a href="http://www.enterasys.com/services/support/contact/">http://www.enterasys.com/services/support/contact/</a>
Internet mail	<b>support@enterasys.com</b> To expedite your message, please type <b>[RoamAbout]</b> in the subject line.

---

To send comments concerning this document to the Technical Publications Department:  
**techpubs@enterasys.com**

---

To expedite your message, please include the document Part Number in the email message.

---

**Before contacting Enterasys Networks for technical support, have the following information ready:**

- Your Enterasys Networks service contract number
- A description of the failure
- A description of any action(s) already taken to resolve the problem (for example, changing mode switches or rebooting the unit)
- The serial and revision numbers of all involved Enterasys Networks products in the network
- A description of your network environment (such as layout, cable type, other relevant environmental information)
- Network load and frame size at the time of trouble (if known)
- The device history (for example, if you have returned the device before, or if this a recurring problem)
- Any previous Return Material Authorization (RMA) numbers

## Conventions Used in This Guide

The following conventions are used in this guide.



**Note:** Calls the reader's attention to any item of information that may be of special importance.



**Caution:** Contains information essential to avoid damage to the equipment.

**Precaución:** Contiene información esencial para prevenir dañar el equipo.

**Achtung:** Verweist auf wichtige Informationen zum Schutz gegen Beschädigungen.



**Electrical Hazard:** Warns against an action that could result in personal injury or death due to an electrical hazard.

**Riesgo Electrico:** Advierte contra una acción que pudiera resultar en lesión corporal o la muerte debido a un riesgo eléctrico.

**Elektrischer Gefahrenhinweis:** Warnung vor sämtlichen Handlungen, die zu Verletzung von Personen oder Todesfällen – hervorgerufen durch elektrische Spannung – führen können!



**Warning:** Warns against an action that could result in personal injury or death.

**Advertencia:** Advierte contra una acción que pudiera resultar en lesión corporal o la muerte.

**Warnhinweis:** Warnung vor Handlungen, die zu Verletzung von Personen oder gar Todesfällen führen können!



---

## Site Preparation

This chapter describes the site requirements for the successful installation of RoamAbout antennas. It also includes brief descriptions of the RoamAbout indoor and outdoor antenna options. This information is intended for sales engineers or site evaluators.

The antennas listed in this document are only for use with the RoamAbout Wireless Access Point RBT-4102 and the Wireless Access Point RBT-1602. Not all antennas listed in this document can be used by both wireless access points. Refer to [Appendix A, Specifications](#), to determine if your access point supports the specified antenna.



**Warning:** Site prerequisites should be verified by a person familiar with national codes, local electrical codes, and with other regulations governing this type of installation. Enterasys Networks, its channel partners, resellers, and distributors assume no liability for personal injury, property damage, or violation of government regulations that may arise from failing to comply with the instructions in this guide.

**Advertencia:** los prerequisites del sitio debe verificarlos una persona que esté familiarizada con los códigos nacionales, códigos eléctricos locales y cualquier otra regulación que aplique con referencia a este tipo de instalación. Enterasys Networks, sus socios, revendedores y distribuidores no se hacen responsables por cualquier daño o perjuicio personal, daños a la propiedad o por la violación de las regulaciones gubernamentales que puedan surgir por no acatar las instrucciones de esta guía.

**Warnhinweis:** Der Installationsort muss von einer qualifizierten Person geprüft werden, die mit den landesweiten und örtlichen Vorschriften und Richtlinien für Installationen dieser Art vertraut ist. Weder Enterasys Networks noch dessen Channel Partner, Reseller oder Distributoren haften für Personen- oder Sachschaden oder Gesetzesverstöße, die auf eine unzureichende Befolgung dieser Anleitung zurückzuführen sind.

## Choosing Antennas for Wireless Network Configurations

The type and number of antennas that you need depend on the configuration of your wireless network. [Table 1-1](#) lists the general type of antenna to use for various wireless network configurations.

**Table 1-1 Antennas for Wireless Network Configurations**

Wireless Network Configuration	Description	Antenna Type
LAN-to-LAN Point-to-Point (RBT-4102 only)	This is a wireless link between two APs that connects two separate wired LANs.	Directional antennas, typically two.
LAN-to-LAN Point-to-Multipoint (RBT-4102 only)	In a point-to-multipoint network, up to nine APs provide wireless links to connect up to nine LANs. One AP is designated as the central (multipoint) AP. The other APs are called endpoints and only communicate with the Central AP.	Omni-Directional antenna - to which the Central AP connects. Directional antennas - to which the Endpoint APs connect.
Wireless Infrastructure	This is an inside/outside wireless network where one or more APs are used to connect clients to a wired LAN.	An Omni-Directional or a sectored antenna.

## Determining the Antenna Locations

The following factors determine the locations where you can place the antennas relative to one another and the distances between them:

- Type of antennas. The RoamAbout antennas are described in [Antenna Models](#) on page 1-9.
- Length of cable connecting the antenna to the AP.
- Data rate required.
- In a LAN-to-LAN network, the distance between the buildings.
- Obstructions in the signal path.
- In a wireless infrastructure network, the area around the antenna where clients need to communicate with the AP.

Typically, the RoamAbout directional and omni-directional antennas are installed on rooftops. The directional antenna can also be installed on the side of a building. The following sections describe the factors that affect the range of the antennas.

### Distances with Cables

[Table 1-2](#) lists the distances for the RBT-4102, RBT-4102-EU, and the RBT-4102 -BG. The distances include the cables at both ends. For every 6 dBi of cable loss, divide the distance by two. For every 10 dBi of cable loss, divide the distance by three.



#### Notes:

- Be sure to calculate the cable loss at both ends, and include the pigtails.
- The distance miles listed are approximate.
- If the RBT-4102-EU uses one 8 dBi (RBTES-BG-M08M) to one or more 14 dBi sector antenna(s), you will get approximately half the distances shown in [Table 1-2](#) using the 2.4 GHz band.

**Table 1-2 Outdoor Distance Matrix Between Antennas (RBT-4102 LAN to LAN/MultiPoint)**

GHz	Antenna	Cables used	Signaling Rate	Throughput	Miles
5.7 - 5.8	RBT-AH-P23M (23 dBi to 23 dBi) For use in North America only.	Pigtail and the LMR-600-C25F at each end	54 Mbit/s	21 Mbit/s	2
			36 Mbit/s	17 Mbit/s	4
			24 Mbit/s	13 Mbit/s	6
			6 Mbit/s	4.5 Mbit/s	8
		Pigtail and the LMR-600-C50F at each end	54 Mbit/s	21 Mbit/s	1.2
			36 Mbit/s	17 Mbit/s	2.4
			24 Mbit/s	13 Mbit/s	3.5
			6 Mbit/s	4.5 Mbit/s	5
		Pigtail and the LMR-400-C50 at each end	54 Mbit/s	21 Mbit/s	0.8
			36 Mbit/s	17 Mbit/s	1.6
			24 Mbit/s	13 Mbit/s	2.3
			6 Mbit/s	4.5 Mbit/s	3.3

**Table 1-2 Outdoor Distance Matrix Between Antennas (RBT-4102 LAN to LAN/MultiPoint)**

GHz	Antenna	Cables used	Signaling Rate	Throughput	Miles
5.7 - 5.8	RBTES-AH-P23M/M0M (23 dBi to 10 dBi) For use in North America only.	Pigtail and the LMR-600-C25F at each end	54 Mbit/s	21 Mbit/s	0.75
			36 Mbit/s	18 Mbit/s	1.5
			24 Mbit/s	13 Mbit/s	2.5
			6 Mbit/s	4.4 Mbit/s	4
		Pigtail and the LMR-600-C50F at each end	54 Mbit/s	21 Mbit/s	0.5
			36 Mbit/s	18 Mbit/s	1
			24 Mbit/s	13 Mbit/s	1.75
			6 Mbit/s	4.4 Mbit/s	2.75
		Pigtail and the LMR-400-C50 at each end	54 Mbit/s	21 Mbit/s	0.3
			36 Mbit/s	18 Mbit/s	0.7
			24 Mbit/s	13 Mbit/s	1.2
			6 Mbit/s	4.4 Mbit/s	1.8
5.4 - 5.7	RBTES-AW-S1590M (15 dBi to 15 dBi) Based on ETSI Standards. (Not allowed in North America)	Pigtail and the LMR-600-C25F at each end	54 Mbit/s	21 Mbit/s	0.5
			36 Mbit/s	18 Mbit/s	1
			24 Mbit/s	13 Mbit/s	1.5
			6 Mbit/s	4.5 Mbit/s	3
		Pigtail and the LMR-600-C50F at each end	54 Mbit/s	21 Mbit/s	0.3
			36 Mbit/s	18 Mbit/s	0.6
			24 Mbit/s	13 Mbit/s	0.9
			6 Mbit/s	4.5 Mbit/s	1.8
		Pigtail and the LMR-400-C50 at each end	54 Mbit/s	21 Mbit/s	0.2
			36 Mbit/s	18 Mbit/s	0.3
			24 Mbit/s	13 Mbit/s	0.6
			6 Mbit/s	4.5 Mbit/s	1.2
2.4 GHz	RBTES-BG-S1490M (14 dBi to 14 dBi) Based on ETSI Standards. (Not allowed in North America)	Pigtail and the LMR-600-C25F at each end	54 Mbit/s	18.3 Mbit/s	0.5
			36 Mbit/s	15.5 Mbit/s	1
			24 Mbit/s	10 Mbit/s	1.5
			6 Mbit/s	4 Mbit/s	3
		Pigtail and the LMR-600-C50F at each end	54 Mbit/s	18.3 Mbit/s	0.4
			36 Mbit/s	15.5 Mbit/s	0.8
			24 Mbit/s	10 Mbit/s	1.2
			6 Mbit/s	4 Mbit/s	2.4
		Pigtail and the LMR-400-C50 at each end	54 Mbit/s	18.3 Mbit/s	0.3
			36 Mbit/s	15.5 Mbit/s	0.6
			24 Mbit/s	10 Mbit/s	0.9
			6 Mbit/s	4 Mbit/s	1.8

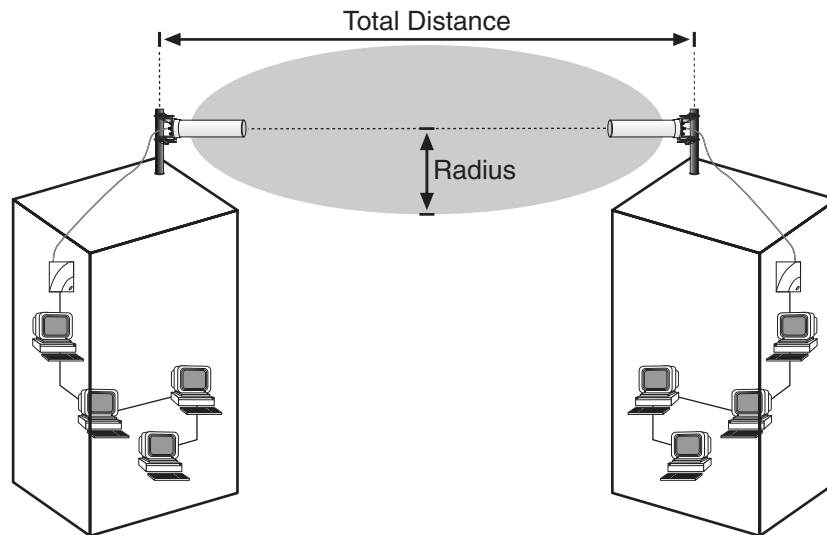


## Line of Sight

The shape of the radio beam, defined as the Fresnel Zone, is widest in the middle. The Fresnel Zone is shown as the gray area between the antennas in [Figure 1-1](#). The exact shape and width of the Fresnel Zone is determined by the distance between the antenna and frequency of the radio signal.

The radius of the radio beam, shown as the lower half of the Fresnel Zone, is the distance from the center of the beam outward in any direction. The length of the radius is not based on the data rate and the type of antenna.

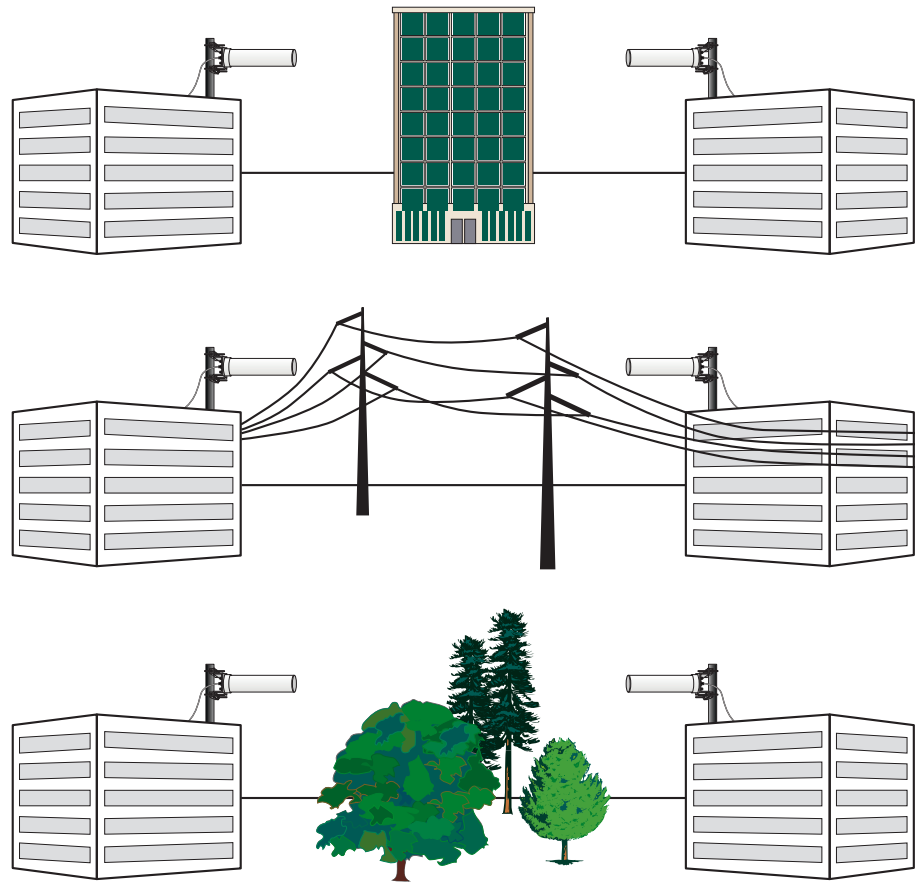
**Figure 1-1 Fresnel Zone and Line of Sight Clearance**



If a significant part of the Fresnel Zone is obstructed, a portion of radio energy is lost, resulting in reduced performance. For optimal performance, ensure that the antenna products you choose, in combination with the height of the antenna installation above ground, provide sufficient clearance to allow your antenna installation to cover the distance between the two sites.

Obstacles within the line of sight can significantly reduce the distance and performance. Obstructions include neighboring buildings, trees, and power lines, as shown in [Figure 1-2](#).

**Figure 1-2 Potential Obstacles to Line of Sight (not to scale)**

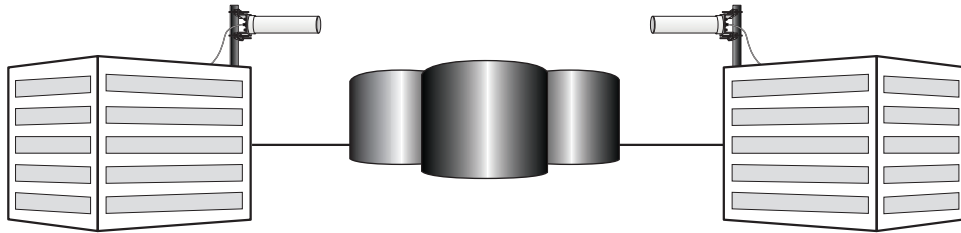


## Other Factors That Can Reduce Antenna Range

Large reflecting surfaces that are parallel or partly perpendicular to the radio signal cause reflections of the radio signal (see [Figure 1-3](#)). Examples of reflecting surfaces are buildings with low-emissivity (low-e) glass, crowded parking lots, water, moist earth, moist vegetation, and above-ground power or telephone lines.

Because surrounding objects, such as trees, power lines, and other antennas, seriously reduce efficiency of the antenna, it is very important to mount the antenna as high and clear of obstacles as possible.

**Figure 1-3 Large Reflecting Surfaces**



## Additional Location Requirements

This section describes other requirements to meet before installing the RoamAbout outdoor antennas.

- Lightning Protection

A lightning rod must be placed close to the antenna mast or wall bracket. This is required to protect the antenna from direct lightning strikes.

- Grounding System

Direct earth grounding of the antenna and the Lightning Protector is necessary to protect the installation from lightning and the build-up of static electricity. The wireless device and the Lightning Protector must be connected to the same earth ground using separate grounds. The antenna and the mounting structure require separate grounds to the same earth ground, using an equipotential bonding conductor. Check with a certified antenna installer, or local electrician, to make sure the antenna is properly grounded.

Ensure that the cable between the antenna and Lightning Protector is at least 0.9 meters (3 feet) away from high-voltage or high-current cable.

- Antenna Height

If you are mounting the antenna on a roof, it must be at least 1.5 meters (5 feet) above the roof line.

If you are mounting the directional antenna to a wall of a building, it must be high enough to achieve a clear line of sight. Mounting an omni-directional antenna to the side of a building can cause signal reflection and reduce distance.



**Note:** The installer is responsible for local building codes.

- AP placement

The AP should be located indoors, and connected to the outdoor antenna using the shortest cable possible to reduce the loss of the cable.

## Antenna Models

The following sections provide brief descriptions of these antennas. Refer to [Chapter 3](#) for antenna installation instructions, and [Appendix A](#) for antenna specifications.

- [Table 1-3](#) lists the RBT-4102 indoor/outdoor antenna models.
- [Table 1-4](#) lists the RBT-4102 indoor only antenna model.
- [Table 1-5](#) lists the RBT-1602 indoor/outdoor antenna models.

**Table 1-3 RBT-4102 Indoor/Outdoor Antenna Options**

Model Number	Name	Frequency	RBT-4102 Country Restrictions
RBTES-BG-M08M	RoamAbout 2.4 GHz 8 dBi Omni-directional Base Station Antenna	2.4 GHz	None.
RBTES-BG-P18M	RoamAbout 2.4 GHz Directional Panel Antenna	2.4 GHz	Can only be used in North America and Japan.
RBTES-BG-S1490M	RoamAbout 2.4 GHz 14 dBi Sector Panel Antenna	2.4 GHz	None.
RBTES-AM-M10M	RoamAbout 5.3 GHz 10 dBi Omni-Directional Antenna	5.3 GHz	Can only be used in North America.
RBTES-AH-M10M	RoamAbout 5.8 GHz 10 dBi Omni-Directional Antenna	5.8 GHz	Can only be used in North America.
RBTES-AH-P23M	RoamAbout 5.8 GHz 23 dBi Panel Antenna	5.8 GHz	Can only be used in North America.
RBTES-AW-S1590M	RoamAbout 4.9 to 5.9 GHz Sector Panel Antenna	4.9 to 5.9 GHz	None.

**Table 1-4 RBT-4102 Indoor Only Antenna Option**

Model Number	Name	Frequency	RBT-4102 Country Restrictions	
RBT4K-AG-IA	802.11a/b/g Range Extender	<ul style="list-style-type: none"> <li>• 2.4 GHz</li> <li>• 5.2—5.8 GHz</li> </ul>	<ul style="list-style-type: none"> <li>• 2.4—2.5 GHz</li> <li>• 4.9—5.9 GHz</li> </ul>	None.

**Table 1-5 RBT-1602 Indoor/Outdoor Antenna Options**

<b>Model Number</b>	<b>Name</b>	<b>Frequency</b>	<b>RBT-1602 Country Restrictions</b>
RBTES-BG-S06180	RoamAbout 2.4 GHz 6 dBi Sector Panel Antenna	2.4 GHz	None.
RBTES-BG-S07120	RoamAbout 2.4 GHz 7 dBi Sector Panel Antenna	2.4 GHz	None.
RBTES-BG-S1060	RoamAbout 2.4 GHz 10 dBi Sector Panel Antenna	2.4 GHz	None.
RBTES-AW-S1460	RoamAbout 5.1-5.9 GHz 14.5 dBi Sector Panel Antenna	5 GHz	None.
RBTES-AW-S12120	RoamAbout 5.1-5.9 GHz 12 dBi Sector Panel Antenna	5 GHz	None.
RBTES-AW-S10180	RoamAbout 5.1-5.9 GHz 10 dBi Sector Panel Antenna	5 GHz	None.

## Cable Options

The RoamAbout low-loss, outdoor, watertight cables that you use to connect the RoamAbout AP to an antenna are available in the lengths listed in [Table 1-6](#).

All cables have Reverse-N Female connectors on both ends.

**Table 1-6 Cable Options and Model Numbers**

Model Number	Description
RBTES-L200-C20F	20 feet (6.1 meters) LMR200
RBTES-L600-C25F	25 feet (7.6 meters) LMR600
RBTES-L400-C50F	50 feet (15.24 meters) LMR400
RBTES-L600-C50F	50 feet (15.24 meters) LMR600
RBTES-L400-C75F	75 feet (22 meters) LMR400

**Note:** Enterasys Networks does not recommend using this cable due to the loss factor.

To ensure you order the right cable length, carefully determine the distance between the locations where you intend to mount the RoamAbout AP and outdoor antenna.



**Note:** Enterasys Networks recommends using LMR600 (part number RBTES-L600-C25/50F) because of the high losses.

## Lightning Protector

[Table 1-7](#) provides information about the RoamAbout Lightning Protector for use with RoamAbout antennas.

**Table 1-7 Lightning Protector**

Model Number	Description
RBTES-AG-LPM	Reverse-N Male on both ends Male connector housing and male center contact.

## RoamAbout Pigtail Connection Options

The RoamAbout Pigtail Connection is a proprietary cable used to connect the RoamAbout Radio Card to a RoamAbout antenna system.

One end of the cable has a proprietary MC-card connector that connects to the RoamAbout Radio Card. The other end has a reverse polarity N-Type male or female connector to connect to your antenna cabling system. Select the connector gender based on your cable configuration.

[Table 1-8](#) lists the RoamAbout pigtail options.

**Table 1-8 Pigtail Options**

Model Number	Description	Cable Configuration
RBT4K-AG-PT20F	<ul style="list-style-type: none"> <li>Reverse SMA Female connector.</li> <li>Reverse-N Female - Female connector housing and female center contact.</li> </ul>	<ul style="list-style-type: none"> <li>When connecting the AP directly to an antenna, or to the lightning protector.</li> <li>When not using a cable between the AP and the Lightning Protector.</li> </ul>
RBTB-AG-PT20M	<ul style="list-style-type: none"> <li>Reverse-N Male - Male connector housing and male center contact.</li> </ul>	Used when connecting the pigtail cable to a cable before connecting it to the lightning protector or antenna.



## Contacting an Antenna Installation Company

Have an antenna installation professional install the outdoor antennas. The antenna installer provides the expertise to properly install, secure, and ground your antenna. The following checklists describe tasks that the installer may need to perform.



**Note:** The antenna installation professional should be licensed or certified in accordance with local regulations.

### Lightning Protection

- Determine the mounting location for the lightning rod (positioned near the antenna).
- Ensure an earth ground location for the antenna structure and Lightning Protector.

### Mounting Requirements

- Determine the type of mounting that is required (tripod, wall mount, etc.).
- Determine the guy wires needed. Typically, three guy wires are needed for each 3 meter (10 foot) section of the mast; for example, 6 meters (20 feet) of mast requires six guy wires.

### Line of Sight

- Determine the mounting location for the antenna.
- Ensure that the back of the antenna is clear.
- Ensure that remote and local antennas can see each other.
- Ensure that no obstacles are in the direct path or within the defined zone of the two sites.
- Consider whether any Radio Frequency (RF) interference is present.

## Installation Requirements

- Determine the best location for the AP.
- Determine the length of cable required from the antenna to the AP.
- Ensure the location has an accessible Ethernet connection.
- Determine the distance between buildings.

You may need to provide the following distances when contacting the antenna installation company:

Distance between the antennas (building-to-building network): \_\_\_\_\_

Coverage area required (wireless infrastructure network configuration): \_\_\_\_\_

Height of building A: \_\_\_\_\_

Height of building B: \_\_\_\_\_

All possible obstacles that can interfere with the defined radius. \_\_\_\_\_

---

## ***AP Placement and Configuration***

This chapter provides information for the antenna installer and network manager to determine where to place the RoamAbout AP and Lightning Protector.

### **Determining the Location of the AP**

The RoamAbout AP connects to a Lightning Protector with a 51-centimeter (20-inch) cable. The Lightning Protector connects to the outdoor antenna with a standard 6.1-meter (20-foot), 7.6-meter (25-foot), 15.24-meters (50-foot), or a 22-meter (75-foot) low-loss cable. A longer cable will decrease the distance achievable between antennas. The ideal location to install your RoamAbout AP and Lightning Protector must satisfy the following requirements:

- The location must be indoors to protect the AP from extreme weather conditions, excessive heat and humidity, and to keep the unit free from vibration and dust.
- The Lightning Protector and antenna mast must be connected to the same earth ground (using separate grounds), as the AC wall outlet ground using an equipotential bonding conductor.
- The location must provide a connection to the network backbone via an Ethernet LAN cable going to a hub, bridge, or directly into a patch panel.
- The location must be close to where the low-loss antenna cable will enter the building. The low-loss cable connecting the antenna to the Lightning Protector should not exceed 75 feet in length for 2.4 GHz, or 50 feet in length for 5 GHz, due to the distance reduction with longer cables.

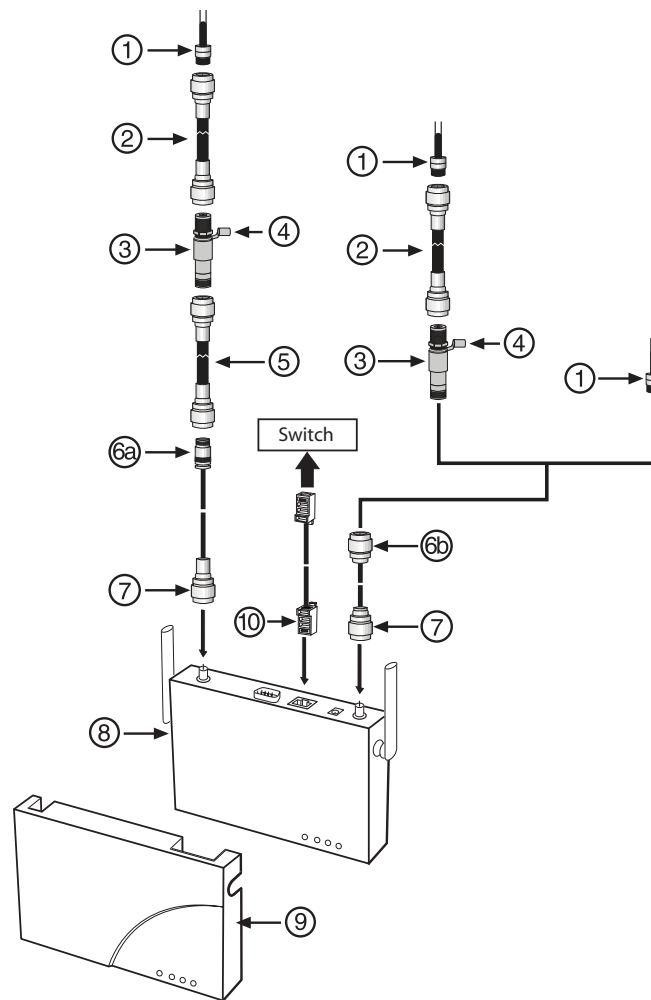
## Overview of Connecting Cables to the Access Point

Before cabling the AP, you should install the AP to a wall or ceiling. For detailed hardware installation procedures, refer to the *RoamAbout Wireless Access Point Hardware Installation Guide* specific to your AP.

### RBT-4102

Figure 2-1 illustrates the RBT-4102 to antenna cable configurations. Table 2-1 lists the RBT-4102 to antenna cable components. Table 2-2 lists the RBT-4102 installation components.

Figure 2-1 RBT-4102 Installation Overview



**Table 2-1 RBT-4102 to Antenna Installation Components**

#	Component
1	Antenna connector (Reverse-N Male)
2	Cable from antenna to Lightning Protector (Reverse-N Female on both ends)
3	Lightning protector (Reverse-N Male on both ends)
4	Lightning Protector ground terminal
5	Cable from Lightning Protector to AP pigtail (Reverse-N Female on both ends)
6a	AP pigtail (Reverse-N Male)
6b	AP pigtail (Reverse-N Female)

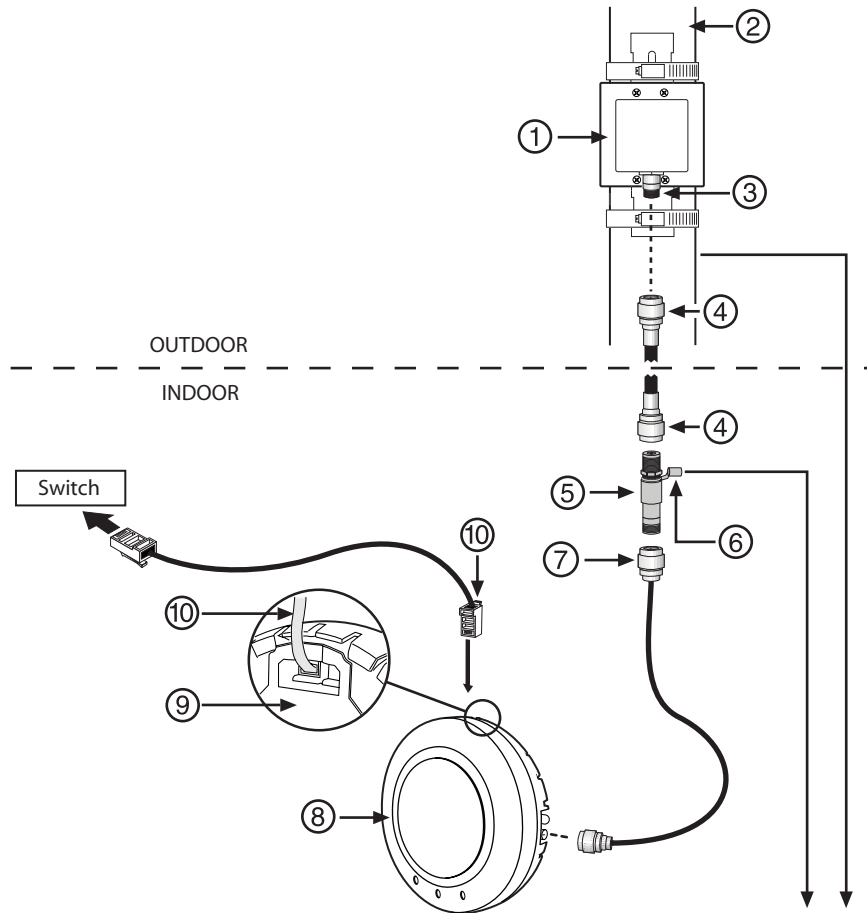
**Table 2-2 RBT-4102 Installation Components**

#	Component
7	AP pigtail connector to AP external antenna connector. 802.11a radio (left side, next to the DC power supply connector) or 802.11 b/g radio (right side, next to the security slot)
8	RBT-4102 Access Point
9	RBT-4102 Access Point cover
10	Connection to switch

## RBT-1602

Figure 2-2 illustrates the RBT-1602 to antenna cable configurations. Table 2-3 lists the RBT-1602 to antenna cable components. Table 2-4 lists the RBT-1602 installation components.

**Figure 2-2 RBT-1602 Installation Overview**



**Table 2-3 RBT-1602 to Antenna Installation Components**

#	Component
1	Antenna
2	Pole
3	Antenna connector
4	Cable
5	Lightning protector
6	Lightning protector ground terminal
7	AP pigtail connector to AP external antenna connector

**Table 2-4 RBT-1602 Installation Components**

#	Component
8	RBT-1602 Access Point
9	RBT-1602 Access Point mounting bracket (dual/redundant 10/100 port)
10	Connection to switch (dual/redundant 10/100 port)

To set up the RoamAbout AP, perform the following steps:

1. Remove the plastic cap from the radio connector(s) and connect it to the pigtail cable.
2. Connect the AP pigtail to the antenna as appropriate for your cable configuration. Refer to [Connecting the Antenna Cables](#) on page 3-34.
3. Connect the Ethernet cable from the AP to the AP connector on the power adapter.
4. Record the AP's MAC address (located on the side of the unit).
5. Record the radio cards' MAC addresses.
6. If you are using PoE, connect the Ethernet cable to your PoE switch.
7. If your switch does not support PoE, you will need to provide an inline power injector, or use the local power option on the RBT-4102.





---

## Antenna Installation

This chapter provides the information necessary for a professional antenna installer to install the RoamAbout antennas.



**Electrical Hazard:** Antennas should only be installed by a qualified antenna installer. The antenna installation professional should be licensed or certified in accordance with local regulations. Do not install the antenna in wet, windy, icy, or otherwise unsafe weather conditions.

**Peligro de descarga eléctrica:** la colocación de la antena debe realizarla un instalador de antenas calificado y con las licencias correspondientes en las regulaciones locales. No instale la antena en condiciones climatológicas adversas, como lluvia, viento, heladas, nieve, etc., que podrían resultar peligrosas.

**Elektrische Spannung:** Antennen dürfen nur von qualifiziertem Fachpersonal installiert werden. Antenneninstallateure müssen den geltenden Vorschriften entsprechend lizenziert oder zugelassen sein. Von Installationsarbeiten bei Nässe, Wind, Frost oder anderen gefährlichen Wetterbedingungen ist abzusehen.



**Note:** Not all antennas in this chapter can be used by both wireless access points. Refer to [Appendix A, Specifications](#), to determine if your access point supports the specified antenna.

The RoamAbout outdoor antenna kits do NOT provide the following items, which may be necessary to install the antenna:

- Mast or other antenna support structure
- Guy wires
- All cables or other hardware necessary for a complete grounding system
- Waterproof tape



**Note:** It is the responsibility of the end-user to ensure that an outdoor antenna installation complies with local radio regulations.

## Installation Overview

The installation process is summarized in the following steps. The following sections in this chapter provide additional details.

1. Make sure the APs are mounted and configured as specified in [Chapter 2](#).
2. Plan and implement a grounding system that meets local electrical codes and safety standards.
3. Install the RoamAbout Lightning Protector.
4. Provide and install an antenna support structure as necessary. Make sure that the support structure is connected to the grounding system.
5. Connect the exposed metal connectors of the low-loss antenna cable to the grounding system.
6. Mount the antenna to the support structure.
7. Connect the antenna cables.
8. Route and connect the low-loss antenna cable to the RoamAbout Lightning Protector that has been installed indoors.
9. Connect the cable assembly from the RoamAbout radio card in the AP to the Lightning Protector.
10. After verifying that the communications link is fully operational, secure all cables and use weatherproofing tape to seal all outdoor connectors.

## Grounding System

Direct earth grounding of the antenna and the Lightning Protector is necessary to protect the installation from lightning and the build-up of static electricity.



**Caution:** The antenna mast, RoamAbout AP, and Lightning Protector must be connected to the same earth ground (with separate grounds), using an equipotential bonding conductor. A good electrical connection should be made to one or more ground rods using at least a 10AWG ground wire and non-corrosive hardware. The grounding system must comply with the National Electrical Code and safety standards that apply in your country. Always check with a qualified electrician to determine whether your outdoor installation is properly grounded.

**Precaución:** el mástil de la antena, RoamAbout AP y el pararrayos deben estar conectados al mismo punto de tierra (con tierras separadas), usando un conductor equipotencial. Se debe lograr una buena conexión eléctrica a una o más de las barras de tierra, usando cable para conexiones a tierra de 10 AWG y equipos inoxidable. El sistema de conexión a tierra debe cumplir con los estándares de seguridad del Código nacional eléctrico que exista en su país. Siempre debe consultar con un electricista calificado para determinar si su instalación de exteriores está conectada a tierra correctamente.

**Achtung:** Der Antennenmast, RoamAbout AP und der Blitzableiter müssen über eine Verbindung mit Potenzialausgleich und einheitlichem Bezugspotenzial separat geerdet sein. Eine sichere elektrische Verbindung zu mindestens einem Erdungsstab ist über ein 10 AWG-Erdungskabel und korrosionsgeschützte Werkstoffe herzustellen. Das Erdungssystem muss den landesweit geltenden Sicherheitsstandards für Elektrizität entsprechen. Lassen Sie die ordnungsgemäße Erdung einer Installation im Freien stets von einem qualifizierten Elektriker prüfen.

The grounding system must satisfy the following requirements:

- The antenna mast, RoamAbout AP, and RoamAbout Lightning Protector must be connected to the same earth ground using an equipotential bonding conductor.
- The antenna and the mounting structure require a separate earth ground connection. Check with a certified antenna installer to make sure the antenna is properly grounded.
- Ensure that the cable between the antenna and Lightning Protector is at least 0.9 meters (3 feet) away from high-voltage or high-current cable.
- A good electrical connection must be made to one or more ground rods, using at least a 10 AWG ground wire and noncorrosive hardware.
- The grounding system must comply with electrical codes and safety standards that apply in your locality.
- Have a qualified electrician verify that your RoamAbout outdoor installation is properly grounded.



**Caution:** A properly installed safety grounding system is necessary to protect your RoamAbout outdoor installation from lightning strikes and static electricity build-up.

**Precaución:** debe instalar correctamente el sistema de conexión a tierra para proteger su instalación de exteriores RoamAbout contra rayos y acumulación de electricidad estática.

**Achtung:** Die RoamAbout-Installation im Freien muss durch ein ordnungsgemäß installiertes, sicheres Erdungssystem vor Blitzschlag und Statikaufbau geschützt sein.

## Lightning Protector Installation

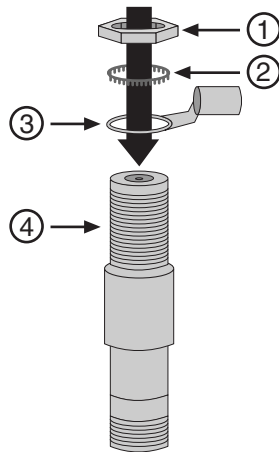
Lightning protection is designed to protect people, property, and equipment by providing a path to the ground whenever lightning strikes your antenna installation. The RoamAbout Lightning Protector is an indispensable part of such a grounding system to protect your electronic equipment from transients and/or electrostatic discharges at the antenna.

For optimal protection, locate the RoamAbout Lightning Protector as follows:

- As close as possible to the point where the antenna cable enters the building.
- To allow connection to the same grounding system as the RoamAbout AP and the antenna mast.

Figure 3-1 illustrates how to install the Lightning Protector. Table 3-1 lists the mounting components.

**Figure 3-1 Lightning Protector Installation**



**Table 3-1 Lightning Protector Mounting Components**

#	Component
1	Hex nut
2	Lock washer
3	Ring terminal
4	Lightning protector

To install the RoamAbout Lightning Protector, perform the following steps:

1. Determine a suitable location for the Lightning Protector as described in [Chapter 2](#).
2. Use lock washer and hex nut to secure ring-terminal to the longer of the threaded ends of the Lightning Protector.
3. Connect ground-wire to ring terminal.
4. Connect the longer threaded end of the protector to a Reverse-N Female cable connected to a RoamAbout Access Point.
5. Connect the shorter threaded end of the protector to a Reverse-N Female cable connected to the antenna.



**Caution:** To avoid damage to the RoamAbout equipment, always install the RoamAbout Lightning Protector between the outdoor antenna installation and the RoamAbout AP or other computing device connected to the outdoor antenna.

**Precaución:** para evitar daños a los equipos RoamAbout, debe asegurarse de instalar el pararrayos RoamAbout Lightning Protector entre la antena para exteriores y el RoamAbout AP o cualquier otro dispositivo electrónico conectado a la antena.

**Achtung:** Zum Schutz der RoamAbout-Ausrüstung ist der RoamAbout-Blitzableiter zwischen der Außenantenne und dem RoamAbout AP oder sonstigen an die Antenne angeschlossenen Computergeräten zu installieren.

## Mounting the Antenna

This section includes requirements and mounting guidelines for the RoamAbout outdoor antennas. Each antenna mounting section contains an illustration of the antenna, component description, and a mounting procedure.

### Selecting a Mast



**Note:** You must supply your own mast on which to mount a RoamAbout antenna. RoamAbout antennas do not come with masts.

To minimize the influence of obstacles, signal interference or reflections, install the antenna at least 2 meters (6 feet) away from all other antennas.

If you need to mount multiple antennas on a single mast, alternate the mounting of directional antennas for vertical and horizontal polarization.

In subfreezing conditions, the communications link could fail if an antenna is exposed to ice buildup or covered with snow.

The mast must satisfy the following requirements:

- The mast must be constructed of sturdy, weatherproof, noncorrosive material such as galvanized or stainless steel construction pipe.
- Mast diameters for each antenna should be as listed in [Table 3-2](#).
- Antenna mast length must be sufficient to allow an antenna height at least 1.5 meters (5 feet) above the roof peak. If the roof is metal, the antenna height should be a minimum of 3 meters (10 feet) above the roof.

**Table 3-2 RoamAbout Antennas Mast Diameters**

Antenna	Part Number	Mast Diameter
RoamAbout 2.4 GHz Omni-Directional	RBTES-BG-M08M	Up to 63.5 mm (2.5 in.) Outside Diameter (OD)
RoamAbout 2.4 GHz Directional Panel	RBTES-BG-P18M	42 mm (1.66 in.) to 73 mm (2.88 in.)
RoamAbout 2.4 GHz Sector Panel	RBTES-BG-S1490M	
RoamAbout 4.9–5.9 GHz Sector Panel	RBTES-AW-S1590M	
RoamAbout 5.3 GHz Omni-Directional	RBTES-AM-M10M	Up to 61 mm (2.4 in.) OD
RoamAbout 5.8 GHz Omni-Directional	RBTES-AH-M10M	
RoamAbout 5.8 GHz Panel	RBTES-AH-P23M	30 mm (1.2 in.) to 50 mm (1.9 in.)
RoamAbout 2.4 GHz 6 dBi Sector Panel	RBTES-BG-S06180	50.8 mm (2 in.)
RoamAbout 2.4 GHz 7 dBi Sector Panel	RBTES-BG-S07120	50.8 mm (2 in.)
RoamAbout 2.4 GHz 10 dBi Sector Panel	RBTES-BG-S1060	50.8 mm (2 in.)
RoamAbout 5.1-5.9 GHz 14.5 dBi Sector	RBTES-AW-S1460	50.8 mm (2 in.)
RoamAbout 5.1-5.9 GHz 12 dBi Sector Panel	RBTES-AW-S12120	50.8 mm (2 in.)
RoamAbout 5.1-5.9 GHz 10 dBi Sector Panel	RBTES-AW-S10180	50.8 mm (2 in.)

## Antenna Polarization

It does not matter what type of polarization you choose for your RoamAbout antennas as long as the antenna at one end of the communications link is mounted in the same plane as the antenna at the other end.

Vertical polarization is standard for the RoamAbout 14 dBi directional antenna.

To minimize the influence of cross-talk between antennas, you might need to mount the antenna for horizontal polarization when:

- Multiple antennas are mounted on the same antenna mast.
- The wireless link transmissions cross another radio beam from a neighboring installation.

## Mounting RoamAbout 2.4 GHz 8 dBi Omni-Directional Base Station Antenna

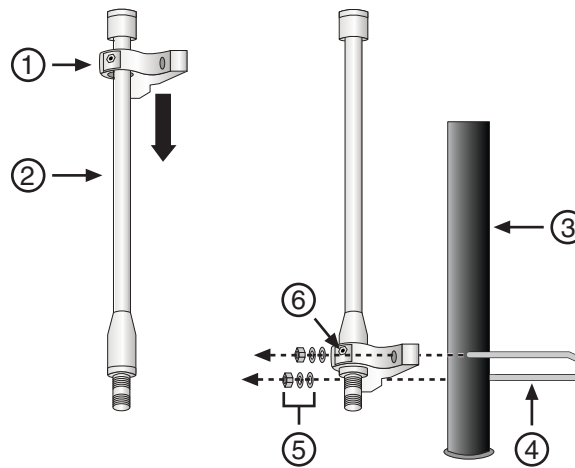
You can mount the RoamAbout 2.4 GHz omni-directional base station antenna (part number RBTES-BG-M08M) on a mast.

The RoamAbout 2.4 GHz omni-directional base station antenna kit includes the following hardware:

- One mounting bracket
- One U-bolt
- Two hex nuts
- Two spring lock washers
- Two flat washers

Figure 3-2 illustrates how to mount the RoamAbout omni-directional base station antenna on a mast in a horizontal polarization mode. Table 3-3 lists the mounting components.

**Figure 3-2 Mounting the 2.4 GHz Omni-Directional Antenna to a Mast**



**Table 3-3 RoamAbout Omni-Directional Base Station Antenna Mounting Components**

#	Component
1	Mount
2	Antenna (RBTES-BG-M08M)
3	Mast (user supplied)
4	U-bolt
5	Washers and nuts for tightening U-bolt to mount
6	Set screws for tightening antenna to mount



To mount the omni-directional base station antenna to a mast, perform the following steps:

1. With the mount situated so that the arrows stamped on its toothed surface face up, insert the top of the antenna through the center hole in the mount.
2. Slide the mount down the antenna until it is seated securely around the base of the antenna.



**Note:** The mount's center hole is tapered to match the taper of the antenna base. The antenna will thus fit snugly into the mount's center hole.

3. Tighten the set screws on the sides of the mount until tight.
4. Place the U-bolt around the mast.
5. Insert the U-bolt ends through the screw holes on the side flange of the mount.
6. Insert the flat and spring lock washers over the U-bolt threaded ends.
7. Thread a hex nut on each end of the U-bolt until each nut is finger tight.
8. Position antenna at desired location along mast and tighten both hex nuts using an Allen wrench.
9. After mounting the antenna, connect the antenna cables as described in "[Connecting the Antenna Cables](#)" on page 3-34.

## Mounting the RoamAbout 2.4 GHz Directional Antenna

You can mount the RoamAbout 2.4 GHz directional antenna (part number RBTES-BG-P18M) on a wide or narrow mast.



**Notes:**

Wide masts have dimensions of 1.25 to 2.5 inches [1.66 to 2.88 Outside Dimensions (OD)] for Schedule 40 pipe.

Narrow masts have dimensions of less than 1.25 inches (1.66 OD) for Schedule 40 pipe.

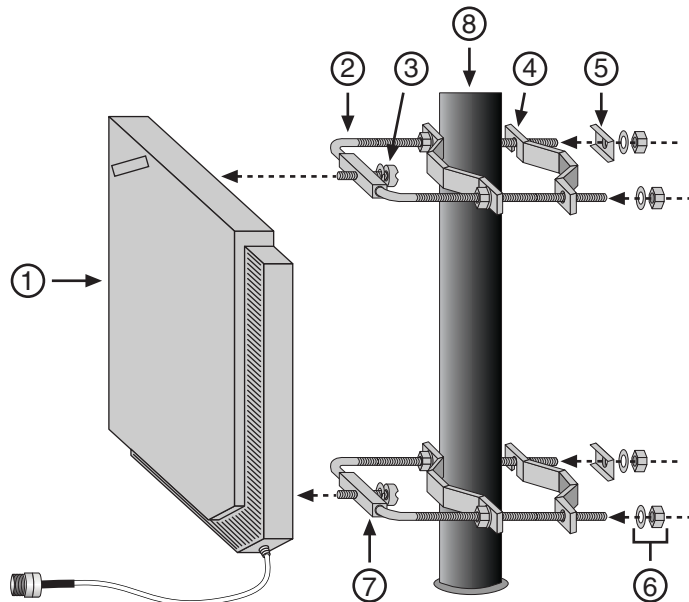
The RoamAbout 2.4 GHz directional antenna kits include the following hardware:

- Two U-brackets
- Four mounting brackets
- Four flat washers, and hex nuts
- Two channel washers

### Mounting on a Wide Mast

Figure 3-3 illustrates how to mount the RoamAbout 2.4 GHz directional antenna on a wide mast. Table 3-4 lists the wide mast mounting components.

**Figure 3-3 Mounting the RoamAbout 2.4 GHz Directional Antenna on a Wide Mast**



**Table 3-4 RoamAbout 2.4 GHz Directional Antenna Wide Mast Mounting Component**

#	Component
1	Antenna (RBTES-BG-P18M)
2	U-bolts
3	Bolt to attach antenna to mount
4	Mounting bracket

**Table 3-4 RoamAbout 2.4 GHz Directional Antenna Wide Mast Mounting Component**

#	Component
5	Channel washer
6	Flat washer and nut
7	Antenna tilt angle adjuster
8	Mast (user supplied)

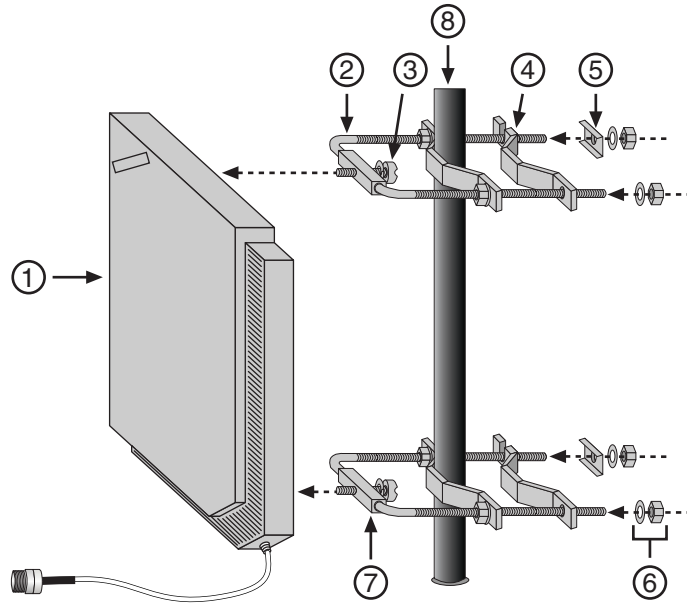
To mount the RoamAbout 2.4 GHz directional antenna to a wide mast, perform the following steps:

1. Loosen the nuts on the open end of the U-bolt until you can swing the notched end of the bracket (side with the channel washer) off of the U-bolt.
2. Insert the U-bolt around the mast.
3. If necessary, to widen the opening between the mounting brackets, turn the nuts for the mounting bracket near the closed end of the U-bolt so that bracket moves towards the closed end of the U-bolt.
4. Swing the notched end of the bracket (nearest the open end of the U-bolt) onto the U-bolt. Tighten the nuts until the brackets grip the mast snugly.
5. Turn the tilt angle adjuster to the angle at which you want to mount the antenna.
6. Repeat steps 1 through 5 to attach the second U-bolt mount to the mast.
7. Connect the antenna to the screws in the middle of the tilt angle adjusters on each U-bolt.
8. After mounting the antenna, connect the antenna cables as described in [“Connecting the Antenna Cables”](#) on page 3-34.

## Mounting On a Narrow Mast

Figure 3-4 illustrates how to mount the RoamAbout 2.4 GHz directional antenna on a narrow mast. Table 3-5 lists the narrow mast mounting components.

**Figure 3-4 Mounting the RoamAbout 2.4 GHz Directional Antenna on a Narrow Mast**



**Table 3-5 RoamAbout 2.4 GHz Directional Antenna Narrow Mast Mounting Components**

#	Component
1	Antenna (RBTES-BG-P18M)
2	U-bolts
3	Bolt to attach antenna to mount
4	Mounting bracket
5	Channel washer
6	Flat washer and nut
7	Antenna tilt angle adjuster
8	Mast (user supplied)

To mount the RoamAbout 2.4 GHz directional antenna to a narrow mast, perform the following steps:

1. Remove the nuts, flat and channel washers from the open end of the U-bolt.
2. Remove the bracket nearest to the open end of the U-bolt.
3. Insert the U-bolt around the mast.
4. Reverse the orientation of the bracket that you removed so that it is on the U-bolt in the same orientation as the other bracket. (That is, with the convex side of the bracket facing the closed end of the U-bolt and the concave side of the U-bolt facing the open end of the U-bolt.)
5. Replace the nuts, flat and channel washers on the ends of the U-bolt.



**Note:** Install the channel washer on the notched side of the bracket.

6. Tighten the nuts until the brackets grip the mast snugly.
7. Turn the tilt angle adjuster to the angle at which you want to mount the antenna.
8. Repeat steps 1 through 7 to attach the second U-bolt mount to the mast.
9. Connect the antenna to the screws in the middle of the tilt angle adjusters on each U-bolt.
10. After mounting the antenna, connect the antenna cables as described in [“Connecting the Antenna Cables”](#) on page 3-34.

## Mounting the RoamAbout 2.4 GHz Sector Panel Antenna

You can mount the RoamAbout 2.4 GHz sector panel antenna (part number RBTES-BG-S1490M) to a wide or narrow mast.



**Notes:**

Wide masts have dimensions of 1.25 to 2.5 inches [1.66 to 2.88 Outside Dimensions (OD)] for Schedule 40 pipe.

Narrow masts have dimensions of less than 1.25 inches (1.66 OD) for Schedule 40 pipe.

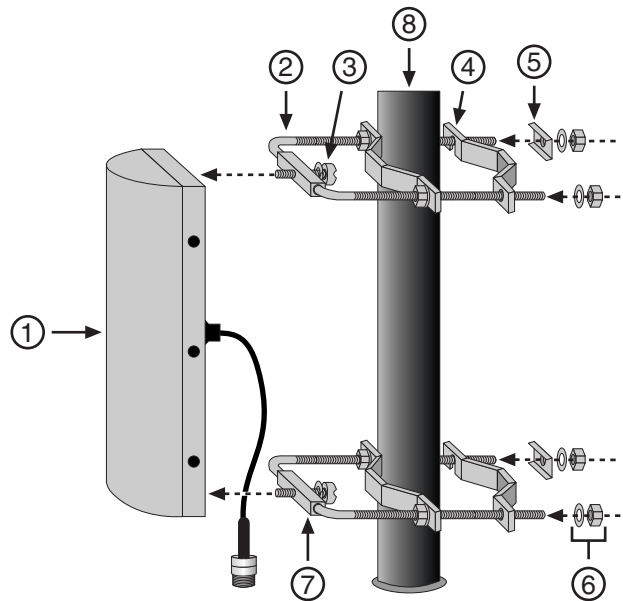
The RoamAbout 2.4 GHz sector panel antenna kit includes the following hardware:

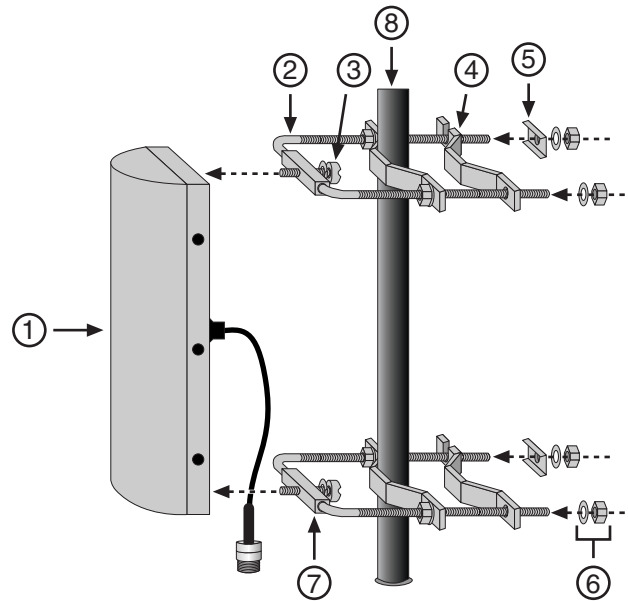
- Two U-brackets
- Four mounting brackets
- Four flat washers, and hex nuts
- Two channel washers

Figure 3-5 and Figure 3-6 illustrate how to mount the 2.4 GHz sector panel antenna on a wide or narrow mast. Table 3-6 lists the mast mounting components.

Refer to “Mounting the RoamAbout 2.4 GHz Directional Antenna” on page 3-10 for the exact instructions for mounting this antenna to a wide or narrow mast.

**Figure 3-5 Mounting Sector Panel Antenna - Wide Mast**



**Figure 3-6 Mounting Sector Panel Antenna - Narrow Mast****Table 3-6 RoamAbout 2.4 GHz Sector Panel Mast Mounting Components**

#	Component
1	Antenna (RBTES-BG-S1490M)
2	U-bolt
3	Bolt to attach antenna to mount
4	Mounting bracket
5	Channel washer
6	Flat washers and nuts
7	Antenna tilt angle adjuster
8	Mast (user supplied)

## Mounting the RoamAbout 2.4 GHz 6 dBi 180 Degree Sector Panel Antenna (RBT-1602 only)

You can mount the RoamAbout 2.4 GHz 6 dBi sector panel antenna (part number RBTES-BG-S06180) to a pole or a solid wall.



**Caution:** The external antenna must be installed at least 20-cm from the access point.



**Caution:** Installation of external antennas must be performed by qualified service personnel only.



**Caution:** On 802.11a antennas, the metal plate attached to the back of the antenna is a reflector plate. The reflector plate is required for antenna operation. Do not reverse or remove this plate.

This section also applies to the following RBT-1602 antennas:

- RoamAbout 2.4 GHz, 7 dBi, 120 Degree Sector Panel Antenna.  
Part number: RBTES-BG-S07120
- RoamAbout 2.4 GHz, 10 dBi, 60 Degree Sector Panel Antenna.  
Part number: RBTES-BG-S1060
- RoamAbout 5.1-5.9 GHz, 10.8 dBi, 180 Degree Sector Panel Antenna.  
Part number: RBTES-AW-S10180
- RoamAbout 5.1-5.9 GHz, 14.5 dBi, 60 Degree Sector Panel Antenna.  
Part number: RBTES-AW-S1460
- RoamAbout 5.1-5.9 GHz, 12.5 dBi, 120 Degree Sector Panel Antenna.  
Part number: RBTES-AW-S12120

The RoamAbout sector panel antennas, and the kit shipped with each antenna, are shown in [Figure 3-7](#).



**Figure 3-7 RBT-1602 Antennas**

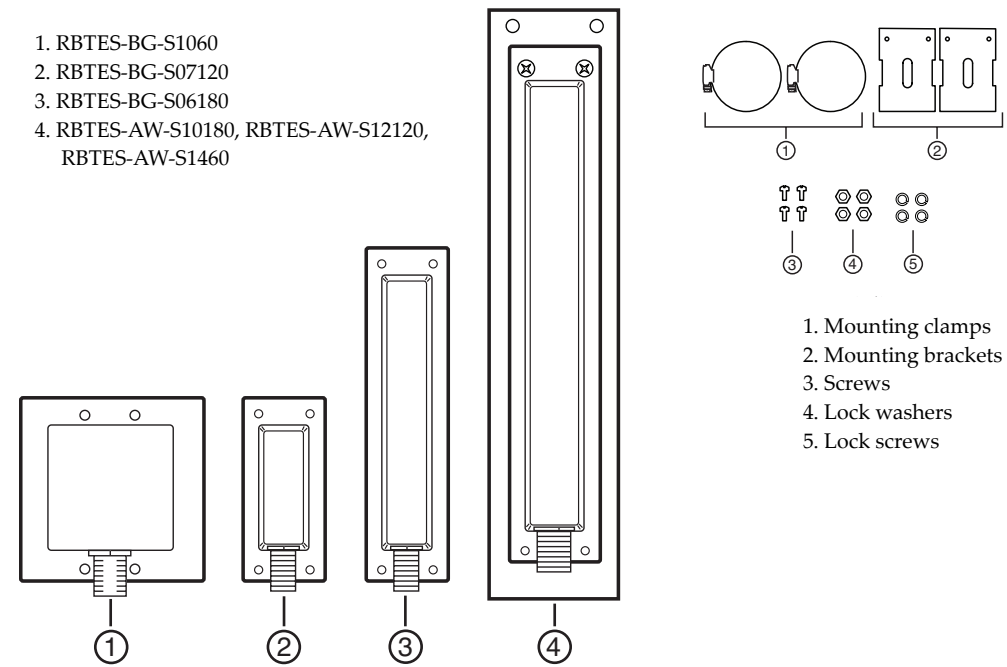
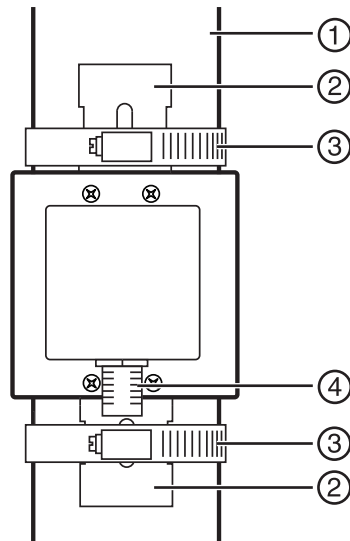


Figure 3-8 illustrates how to mount the 2.4 GHz 6 dBi sector panel antenna. Table 3-6 lists the mounting components.

**Figure 3-8 Mounting 2.4 GHz 6 dBi Sector Panel Antenna**



**Table 3-7 RoamAbout 2.4 GHz 6 dBi Sector Panel Mast Mounting Components**

#	Component
1	Pole
2	Mounting bracket

**Table 3-7 RoamAbout 2.4 GHz 6 dBi Sector Panel Mast Mounting Components (continued)**

#	Component
3	Clamp
4	Connector

### Pole Installation

To mount the antenna on a pole, perform the following steps:

1. Attach the pole-mounting brackets to the antenna:
  - a. Place one of the pole-mounting brackets against the back of the antenna, and align the screw holes over two screw holes in the antenna.  
 Make sure the large slot in the bracket is not behind the antenna. If it is, turn the bracket around.
  - b. Insert two of the screws in the mounting kit into the antenna screw holes.
  - c. Place a lock washer and nut on the other end of each screw, and tighten to fasten the bracket to the antenna.
  - d. Repeat for the other bracket.
2. Place the mounting clamps on the pole.  
 If you cannot slide the clamps over the top of the pole, completely loosen the clamps until they come apart, then refasten them after placing them around the pole.
3. Align the clamps around the cutouts in the sides of the pole-mounting brackets, then tighten the clamps to fasten the antenna in place.

### Solid Wall Installation

To attach the antenna to a wall, perform the following steps:

1. Prepare the screw holes as follows:
  - a. Hold the antenna (or mounting plate) in the desired installation location and mark the wall in the locations of the screw holes. The mounting plate is not included.
  - b. If necessary, drill pilot holes for the screws.
  - c. If necessary, insert drywall anchors into the holes.
  - d. Align the antenna or mounting plate screw holes over the holes you prepared.
2. Insert the screws into the holes to fasten the antenna to the wall. If you are using a mounting plate, attach the antenna to the plate, then attach the plate to the wall.



**Note:** The screws in the mounting kit are for attaching the antenna to the pole mounting brackets, and might not be appropriate for the wall or mounting plate.

## Mounting the RoamAbout 2.4 GHz 7 dBi 120 Degree Sector Panel Antenna

Part number: RBTES-BG-S07120

Refer to “[Mounting the RoamAbout 2.4 GHz 6 dBi 180 Degree Sector Panel Antenna \(RBT-1602 only\)](#)” on page 3-16 for antenna information and installation instructions.

## Mounting the RoamAbout 2.4 GHz 10 dBi 60 Degree Sector Panel Antenna

Part number: RBTES-BG-S1060

Refer to “[Mounting the RoamAbout 2.4 GHz 6 dBi 180 Degree Sector Panel Antenna \(RBT-1602 only\)](#)” on page 3-16 for antenna information and installation instructions.

## Mounting the RoamAbout 5.1-5.9 GHz 10.8 dBi 180 Degree Sector Panel Antenna

Part number: RBTES-AW-S10180

Refer to “[Mounting the RoamAbout 2.4 GHz 6 dBi 180 Degree Sector Panel Antenna \(RBT-1602 only\)](#)” on page 3-16 for antenna information and installation instructions.

## Mounting the RoamAbout 5.1-5.9 GHz 14.5 dBi 60 Degree Sector Panel Antenna

Part number: RBTES-AW-S1460

Refer to “[Mounting the RoamAbout 2.4 GHz 6 dBi 180 Degree Sector Panel Antenna \(RBT-1602 only\)](#)” on page 3-16 for antenna information and installation instructions.

## Mounting the RoamAbout 5.1-5.9 GHz 12.5 dBi 120 Degree Sector Panel Antenna

Part number: RBTES-AW-S12120

Refer to “[Mounting the RoamAbout 2.4 GHz 6 dBi 180 Degree Sector Panel Antenna \(RBT-1602 only\)](#)” on page 3-16 for antenna information and installation instructions.

## Mounting the RoamAbout 5.3 and 5.8 GHz Omni-Directional Antennas

You can mount the RoamAbout 5.3 GHz (RBTES-AM-M10M) and 5.8 GHz (RBTES-AH-M10M) omni-directional antennas to a mast or a wall.

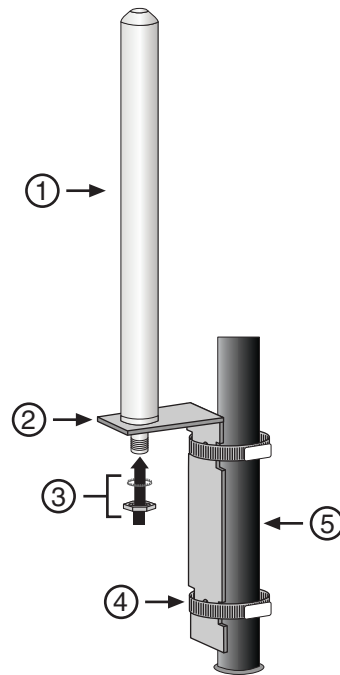
The RoamAbout 5.3 and 5.8 GHz omni-directional antenna kits include the following hardware:

- One mounting bracket
- One hex nut
- One lock washer
- Two hose-type clamps

## Mounting On a Mast

Figure 3-9 illustrates how to mount the RoamAbout 5.3 and 5.8 GHz omni-directional antennas on a mast. Table 3-8 lists the mast mounting components.

**Figure 3-9 Mast Mounting the 5.3 and 5.8 GHz Omni-Directional Antenna**



**Table 3-8 5.3 and 5.8 GHz Omni-Directional Antenna Mast Mounting Components**

#	Component
1	Antenna (RBTES-AH-M10M) or (RBTES-AM-M10M)
2	Mounting bracket
3	Lock washer and hex nut for securing antenna to mount
4	Clamps
5	Mast (user supplied)

To mount a 5.3 or 5.8 GHz omni-directional antenna to a mast, perform the following steps:

1. Insert the connector end of the antenna through the large hole in the mounting bracket.
2. Insert the washer over the antenna connector end.
3. Thread the nut over the antenna connector end until the nut is finger tight.
4. Tighten the hex nut with a wrench.
5. Place each of the clamps into each of the notches on the sides of the bracket.
6. Place clamps over the top of the mast.
7. Align top of bracket with top of mast and tighten clamps to secure bracket to mast.



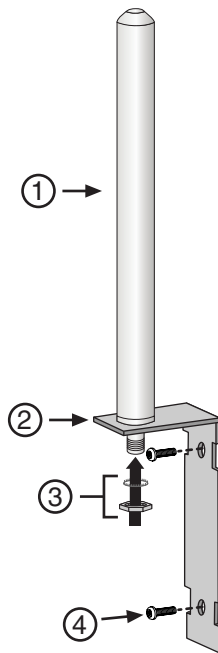
**Note:** Do not allow the top surface of the bracket to exceed the top of the mast.

8. After mounting the antenna, connect the antenna cables as described in “[Connecting the Antenna Cables](#)” on page 3-34.

## Mounting On a Wall

[Figure 3-10](#) illustrates how to mount the RoamAbout 5.3 and 5.8 GHz omni-directional antennas on a wall. [Table 3-9](#) lists the wall mounting components.

**Figure 3-10 Wall Mounting the 5.3 and 5.8 GHz Omni-Directional Antenna**



**Table 3-9 5.3 and 5.8 GHz Omni-Directional Antenna Wall Mounting Components**

#	Component
1	Antenna (RBTES-AH-M10M) or (RBTES-AM-M10M)
2	Mounting bracket
3	Lock washer and hex nut for securing antenna to mount
4	Screws for fastening bracket to wall

**Note:** The antenna kit does not include the screws required to fasten the bracket to wall.

To mount a 5.3 or 5.8 GHz omni-directional antenna to a wall, perform the following steps:

1. Insert the connector end of the antenna through the large hole in the mounting bracket.
2. Insert the washer over the antenna connector end.
3. Thread the nut over the antenna connector end until the nut is finger tight.
4. Tighten the hex nut with a wrench.

5. Position the long end of the mounting bracket containing screw holes flat against the wall where you want to fasten it.
6. Fasten the bracket to wall with a screw in each of the screw holes.



**Note:** Screws for mounting the bracket to the wall do not come with the antenna kit.

7. After mounting the antenna, connect the antenna cables as described in [“Connecting the Antenna Cables”](#) on page 3-34.

## Mounting the RoamAbout 5.8 GHz Panel Antenna

You can mount the RoamAbout 5.8 GHz panel antenna (RBTES-AH-P23M) to a wall or a mast.

The RoamAbout 5.8 GHz panel antenna kit includes the following hardware:

- One antenna bracket
- Two mast brackets
- Two carriage bolts
- Two hex nuts and lock washers for carriage bolts
- Four (yellow) hex nuts
- Four (silver) nuts with lock washers and nuts

To mount the antenna refer to the following sections:

- [“Mounting the Antenna to a Wall”](#) on page 3-22
- [“Mounting the Antenna to a Mast”](#) on page 3-25

### Mounting the Antenna to a Wall

Mounting the antenna to a wall requires the following steps:

1. Marking screw holes on wall
2. Attaching the antenna bracket to the antenna
3. Attaching the antenna to a wall

#### Marking Screw Holes On The Wall

Prior to attaching the antenna bracket to the antenna, use the bracket to determine the position and size of holes that you must make in wall.

To determine position and size of holes in wall, perform the following steps:

1. Situate the antenna bracket with an end against the wall oriented to be able to pivot:
  - side to side when using vertical polarization
  - up and down when using horizontal polarization



**Note:** Both ends of the antenna bracket pivot. You connect an end to the antenna to pivot in the direction of the polarization you wish to use, and an end to the wall that pivots in the opposite direction as indicated above.

2. Mark the wall with the position and size of the antenna bracket screw holes.

- Obtain the proper screws to secure the antenna bracket to this wall surface.

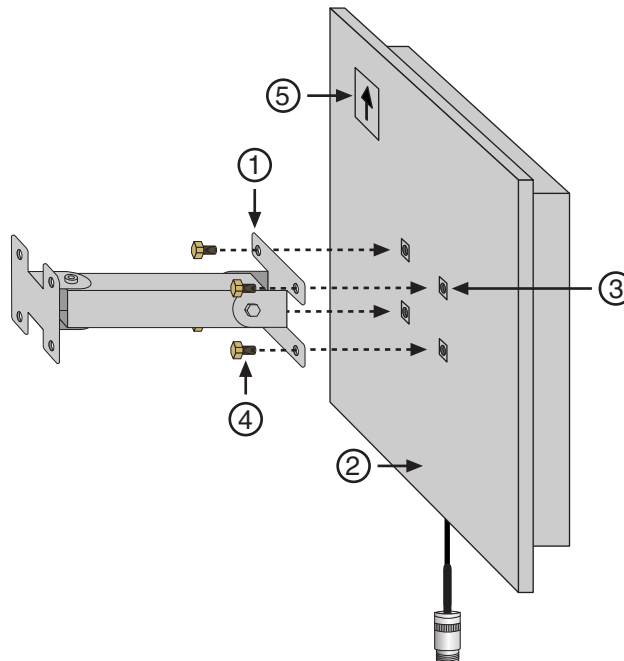


**Note:** This antenna does not ship with screws for attaching the antenna bracket to a wall.

### Attaching the Antenna Bracket to the Antenna

Figure 3-11 illustrates how to attach the antenna bracket to the 5.8 GHz panel antenna. Table 3-10 lists the components for this procedure.

**Figure 3-11 Attaching Antenna Bracket to RoamAbout 5.8 GHz Panel Antenna**



**Table 3-10 RoamAbout 5.8 GHz Panel Antenna Bracket Mounting Components**

#	Component
1	Antenna bracket
2	Antenna (RBTES-AH-P23M)
3	Screw holes to attach bracket to antenna
4	Screws to attach bracket to antenna
5	Label showing direction of antenna vertical polarization

To attach the antenna bracket to the antenna, perform the following steps:

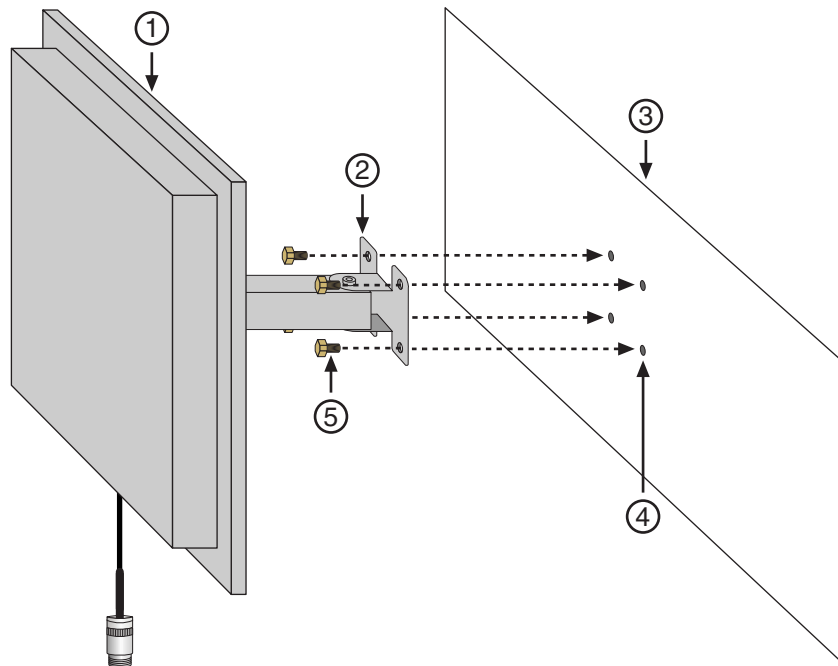
- Place the antenna so that the side with screw holes is facing up.
- Use the polarization label on the upper left corner of the antenna to orient the antenna with the correct polarization.

3. Situate the antenna bracket against the antenna, so that the end against the antenna pivots in the same plane as the desired polarization. For example, if using vertical polarization, this antenna bracket end should pivot up and down. If using horizontal polarization, this antenna bracket end should pivot from side-to-side.
4. Use the four (yellow) hex nuts, to secure the antenna bracket to the back of the antenna.
5. Rotate the pivot of the bracket end attached to the antenna to adjust the antenna position. Lock bracket in desired position by tightening nuts on either side of bracket end with wrenches.

### Mounting the Antenna to a Wall

Figure 3-12 illustrates how to attach the 5.8 GHz panel antenna to a wall. Table 3-11 lists the components for this procedure.

**Figure 3-12 Mounting the RoamAbout 5.8 GHz Panel Antenna to a Wall**



**Table 3-11 RoamAbout 5.8 GHz Panel Antenna Wall Mounting Components**

#	Component
1	Antenna (RBTES-AH-P23M)
2	Antenna bracket
3	Wall
4	Screw holes in wall
5	Screws for attaching antenna to the wall (user supplied)



To attach the antenna bracket to the wall, perform the following steps:

1. Place the antenna bracket against the wall where you want to attach antenna.
2. Secure the antenna bracket to the wall with screws (user provided) in the four screw holes in the pivot bracket.
3. Rotate the pivot of the bracket end attached to the wall to adjust the antenna position. Lock bracket end in desired position by tightening nuts on either side of bracket end with wrenches.

## Mounting the Antenna to a Mast

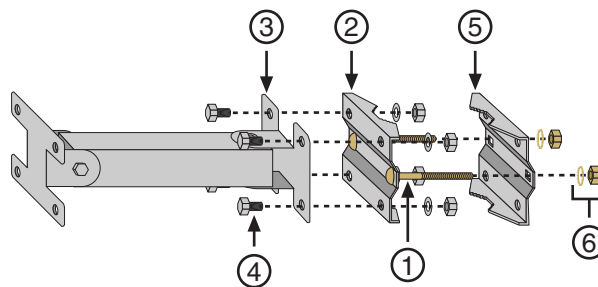
Mounting the antenna to a mast requires the following major steps:

- Attaching the mast brackets to the antenna bracket
- Attaching the antenna bracket to the antenna
- Mounting the antenna to the mast

### Attaching the Mast Brackets to the Antenna Bracket

Figure 3-13 illustrates how to attach mast brackets to the 5.8 GHz panel antenna bracket. Table 3-12 lists the components for this procedure.

**Figure 3-13 RoamAbout 5.8 GHz Panel Antenna Mast Mounting Configuration**



Prior to attaching the mast bracket to the antenna bracket, you must first determine which end of the antenna bracket you will attach to the antenna.

Determine which end of the antenna bracket to attach to the antenna as follows:

1. Place the antenna so that the side with screw holes is facing up.
2. Use the polarization label on the upper left corner of the antenna to orient the antenna with the correct polarization.
3. Situate the antenna bracket against the antenna so that the end against the antenna pivots in the same plane as the desired polarization. For example, if using vertical polarization, this antenna bracket end should pivot up and down. If using horizontal polarization, this antenna bracket end should pivot from side-to-side.
4. When ready, attach the mast bracket to the end of the antenna bracket opposite the end that you determined you will attach to the antenna by following the steps in the next procedure.

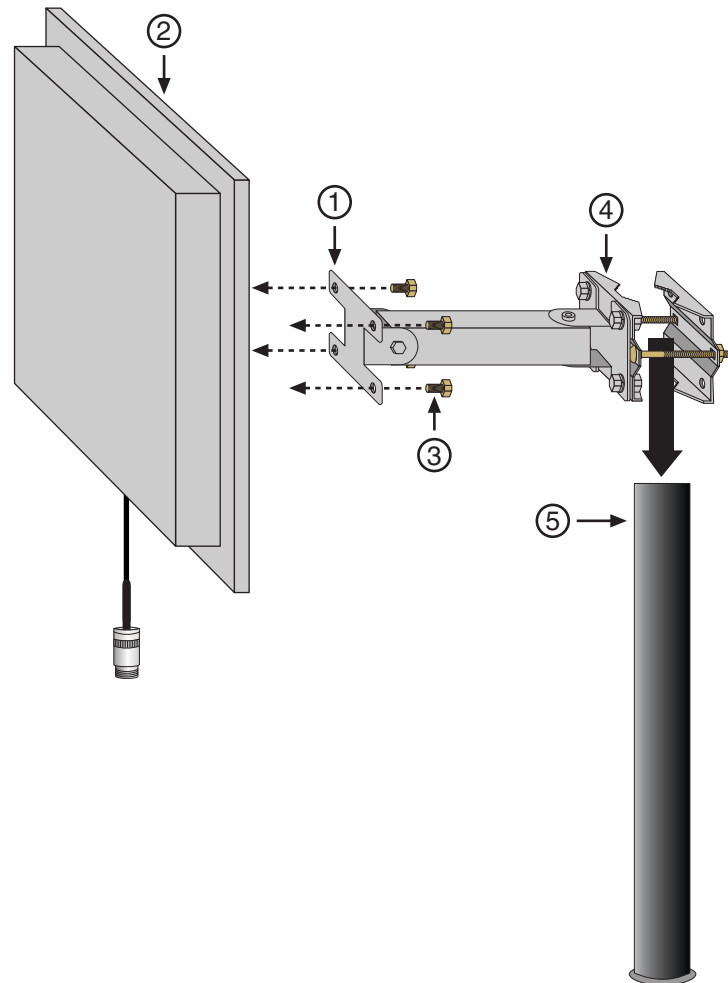
To attach the mast brackets to the antenna bracket, perform the following steps:

1. Insert the carriage bolts from the flat side of one of the mast brackets through the square holes until the carriage bolt head is flush against the bracket.
2. Attach the flat end of this mast bracket to the antenna bracket (opposite the end that you determined you will attach to the antenna) as follows:
  - a. Orient the mast bracket so that the V-ends are on the top and bottom.
  - b. Line up the flat side of the mast bracket flush against the antenna bracket so that the carriage bolt heads are sandwiched between the two brackets.
  - c. Insert each of the four silver screws from the antenna bracket side and secure the two brackets with lock washers and nuts threaded onto the screws from the mast bracket side.
3. Attach the second mast bracket to the first mast bracket as follows:
  - a. Orient the mast bracket so that the V-ends are on the top and bottom facing the other mast bracket
  - b. Insert the carriage bolts through the square holes in the mast bracket
  - c. Secure the mast bracket to the carriage bolt with the (yellow) lock-washers and nuts threaded from the flat side of the mast bracket.

## Attaching the Bracket to the Antenna

Figure 3-14 illustrates how to attach the antenna bracket to the 5.8 GHz panel antenna. Table 3-12 lists the components for this procedure.

**Figure 3-14 Attaching the 5.8 GHz Panel Antenna Bracket to the Antenna**



**Table 3-12 5.8 GHz Panel Antenna Bracket to Antenna Components**

#	Component
1	Antenna bracket
2	Antenna (RBTES-AH-P23M)
3	Screws for attaching antenna bracket to the antenna
4	Mast brackets
5	Mast (user supplied)

To attach the antenna bracket to the antenna, perform the following steps:

1. Place the antenna so that the side with screw holes is facing up.
2. Use the polarization label on the upper left corner of the antenna to orient the antenna with the correct polarization.
3. Situate the antenna bracket against the antenna, so that the end against the antenna pivots in the same plane as the desired polarization. For example, if using vertical polarization, this antenna bracket end should pivot up and down. If using horizontal polarization, this antenna bracket end should pivot from side-to-side.
4. Use the four (yellow) hex nuts, to secure the antenna bracket to the back of the antenna.
5. Rotate the pivot of the bracket end attached to the antenna to adjust the antenna position. Lock bracket in desired position by tightening nuts on either side of bracket end with wrenches.

### **Mounting the 5.8 GHz Panel Antenna to the Mast**

[Figure 3-14](#) illustrates how to mount the 5.8 GHz panel antenna to the mast. [Table 3-12](#) lists the components for this procedure.

To mount the antenna to the mast, perform the following steps:

1. Adjust the size of the opening between the mast brackets so that it approximates the size of the mast. Turn the carriage bolt nuts towards or away from the mast bracket to slide it towards or away from the other mast bracket.
2. Slide mast mounts over the top of the mast.
3. Tighten the carriage bolt nuts until the mast brackets grip the mast snugly.
4. Rotate the pivot of the bracket end attached to the mast to adjust the antenna position. Lock bracket end in desired position by tightening nuts on either side of bracket end with wrenches.

## Mounting the RoamAbout 4.9 to 5.9 GHz Sector Panel Antennas

You can mount the RoamAbout 4.9 to 5.9 GHz sector panel antenna (RBTES-AW-S1590M) to a wide or narrow mast.



**Notes:** Wide masts have dimensions of 1.25 to 2.5 inches [1.66 to 2.88 Outside Dimensions (OD)] for Schedule 40 pipe.

Narrow masts have dimensions of less than 1.25 inches (1.66 OD) for Schedule 40 pipe.

The RoamAbout 4.9 to 5.9 GHz sector panel antenna kit includes the following hardware:

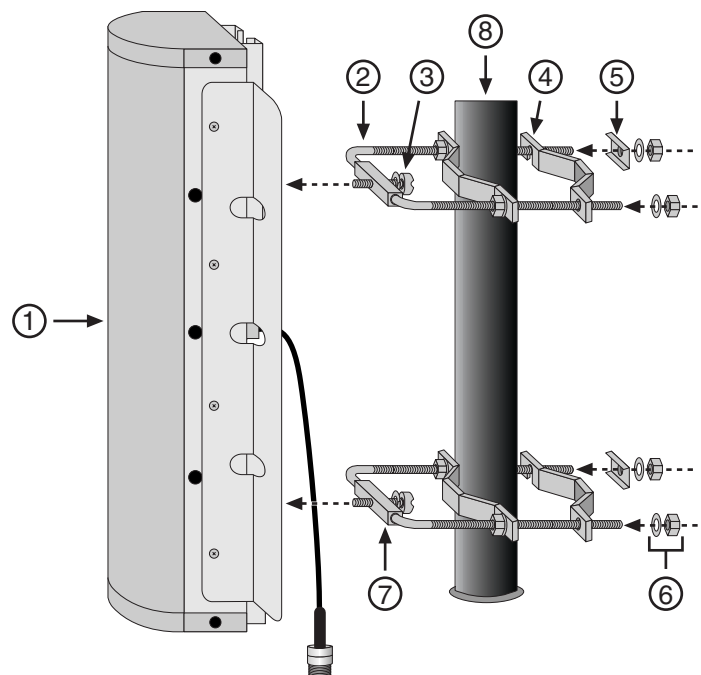
- Two U-brackets
- Four mounting brackets
- Four flat washers, and hex nuts
- Two channel washers
- Two external flaps
- Eight screws and flat washers (for external flap installation)

[Figure 3-15](#) and [Figure 3-16](#) illustrate how to mount the 4.9 to 5.9 GHz sector panel antenna on a wide or narrow mast. [Table 3-13](#) lists the mast mounting components.

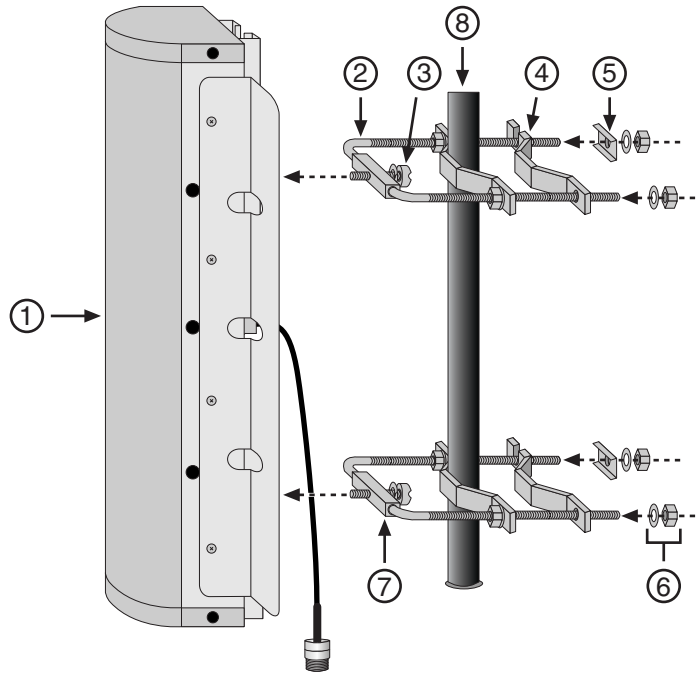
Refer to “[Mounting the RoamAbout 2.4 GHz Directional Antenna](#)” on page 3-10 for the exact instructions for mounting this antenna to a wide or narrow mast.

If you desire to use a 60 degree horizontal beamwidth, refer to the procedure following [Table 3-14](#) to install optional external flaps on both sides of the antenna as shown in [Figure 3-17](#).

**Figure 3-15 Mounting RoamAbout 4.9 to 5.9 GHz Sector Panel Antenna — Wide Mast**

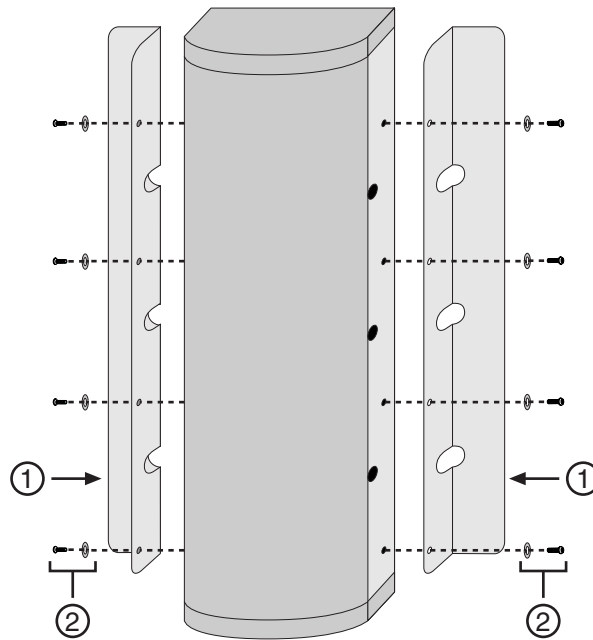


**Figure 3-16 Mounting RoamAbout 4.9 to 5.9 GHz Sector Panel Antenna—Narrow Mast**



**Table 3-13 RoamAbout 4.9 to 5.9 GHz Sector Panel Mast Mounting Components**

#	Component
1	Antenna (RBTES-AW-S1590M)
2	U-bolts
3	Bolt to attach antenna to mount
4	Mounting bracket
5	Channel washer
6	Flat washer and nut
7	Antenna tilt angle adjuster
8	Mast (user supplied)

**Figure 3-17 Installing External Flaps for 4.9 to 5.9 GHz Sector Panel Antenna****Table 3-14 RoamAbout 4.9 to 5.9 GHz Sector Panel External Flaps Components**

#	Component
1	External flap
2	Screw and washer

To attach the external flaps to the antenna, perform the following steps:

1. Place the side of a flap with screw holes flat against one of the sides of the antenna so that the side of the flap that sits perpendicular to the antenna faces the front of the antenna.
2. Attach the flap to the antenna using a screw and washer in each of the four screw holes.
3. Repeat steps 1 and 2 to attach a flap to the other side of the antenna.

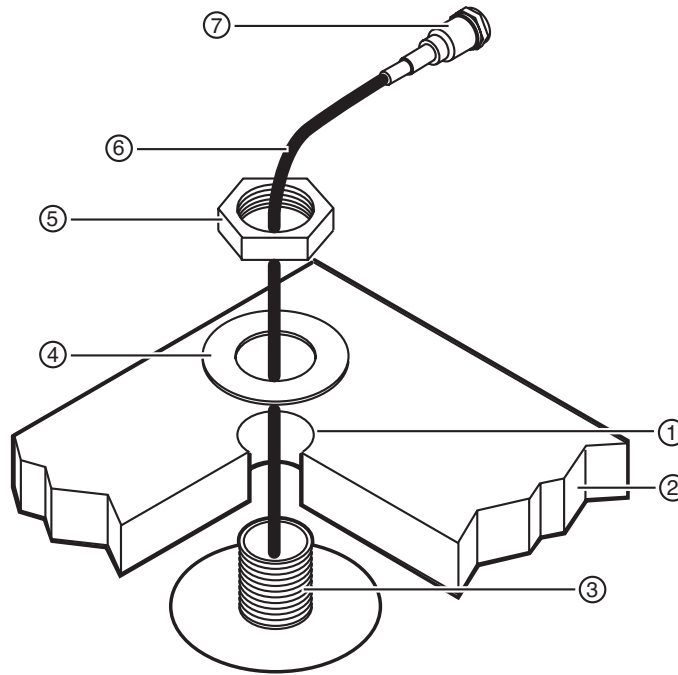
## Mounting the 802.11a/b/g Range Extender (Omni-Directional) Antenna

You can mount the RoamAbout 802.11a/b/g range extender omni-directional antenna (part number RBT4K-AG-IA) using the ceiling mount. The range extender antenna ships with an attached eight-foot cable.

### Using the Ceiling Mount

Figure 3-18 illustrates how to mount the 802.11a/b/g Range Extender omni-directional antenna from a ceiling. Table 3-15 lists the ceiling mount components.

**Figure 3-18 Mounting the 802.11a/b/g Range Extender Antenna to the Ceiling**



**Table 3-15 802.11a/b/g Range Extender Antenna Ceiling Mount Components**

#	Component
1	Ceiling area for cable and connector pass-through.
2	Antenna (RBT4K-AG-IA) ceiling base support.
3	Threaded part of antenna.
4	Lock washer.
5	Lock nut.
6	Eight-foot cable.
7	Antenna SMA Connector.



To mount the 802.11a/b/g range extender omni-directional antenna from a ceiling, perform the following steps:

1. Survey the area for the best location for the antenna.
2. Run the cable from the access point to the desired location.
3. Drill a 3/4-inch (2cm) hole through the ceiling surface at the desired location.  
(Maximum ceiling thickness: 3/4-inch (2 cm))
4. Insert the antenna cabling into the ceiling. Replace the ceiling tile, if necessary.
5. Push the threaded part of the antenna through the hole.
6. Pass the cable through the washer and the nut, and tighten the nut moderately on the opposite side of the ceiling.
7. Attach the cable to the antenna connector.
8. After mounting the antenna, connect the antenna cables as described in [“Connecting the Antenna Cables”](#) on page 3-34.

## Connecting the Antenna Cables

The cable configuration that you use to connect your RoamAbout AP to an outdoor antenna varies based on whether you use:

- A male or a female pigtail connector on your AP
- A Lightning Protector

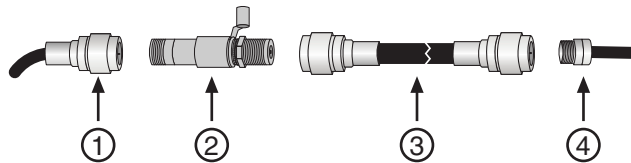
The following sections show the various cable configurations.

### Using the Female Pigtail

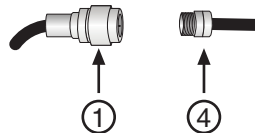
Figure 3-19 and Figure 3-20 show the cable configurations for using a female pigtail connector to connect an AP to an outdoor antenna.

Figure 3-19 shows the configuration for using a Lightning Protector. Figure 3-20 shows the configuration when not using a Lightning Protector. Table 3-16 describes the configurations.

**Figure 3-19 Female Pigtail Cable With Lightning Protector**



**Figure 3-20 Female Pigtail Cable Without Lightning Protector**



**Table 3-16 Female Pigtail Cable Configuration Components**

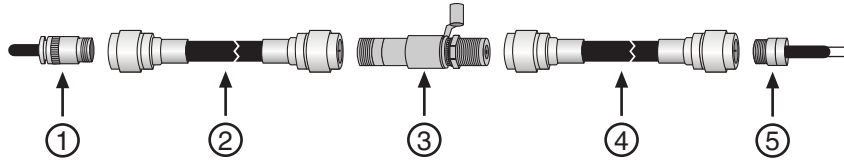
#	Component	Connectors
1	RoamAbout pigtail connection (20-inch) - Female	<ul style="list-style-type: none"> <li>• Reverse-SMA female connector to AP</li> <li>• Reverse-N Female to antenna Female connector housing and female center contact.</li> </ul>
2	Lightning protector	Reverse-N Male on both ends Male connector housing and male center contact.
3	Low-loss antenna cable (lengths of 20, 25, 50 or 75 feet)	Reverse-N Female on both ends Female connector housing and female center contact.
4	Outdoor antenna cable	Reverse-N Male Male connector housing and male center contact.

## Using The Male Pigtail

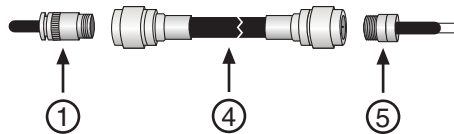
Figure 3-21 and Figure 3-22 show the cable configurations for using a male pigtail connector to connect an AP to an outdoor antenna.

Figure 3-21 shows the configuration for using a Lightning Protector. Figure 3-22 shows the configuration when not using a Lightning Protector. Table 3-17 describes the configurations.

**Figure 3-21 Male Pigtail Cable With Lightning Protector**



**Figure 3-22 Male Pigtail Cable Without Lightning Protector**



**Table 3-17 Male Pigtail Cable Components**

#	Component	Connectors
1	RoamAbout pigtail connection (50 cm) - Male	<ul style="list-style-type: none"> <li>Right Angle MC Card to AP</li> <li>Reverse-N Male to antenna Male connector housing and male center contact.</li> </ul>
2	Low-loss antenna cable (lengths of 20, 25, 50 or 75 feet)	Reverse-N Female on both ends Female connector housing and female center contact.
3	Lightning protector	Reverse-N Male on both ends Male connector housing and male center contact.
4	Low-loss antenna cable (lengths of 20, 25, 50 or 75 feet)	Reverse-N Female on both ends Female connector housing and female center contact.
5	Outdoor antenna cable	Reverse-N Male Male connector housing and male center contact.

## Antenna Cable Route

The cable should not be installed into tight positions, as bending or applying excessive force to the connectors may damage the antenna cable. Always allow the cable to bend naturally around corners.

The low-loss antenna cable must be secured along its complete length. No part of the cable should be allowed to hang free. This is particularly important for cable parts that are installed outdoors. The antenna cables and cable connectors are not designed to withstand excessive force:

- Do not use connectors as cable grips to pull cable through raceways or conduits.
- Do not use cable connectors to support the weight of the cable during or after installation.
- Do not use tools to tighten connectors (finger-tighten only).

## Connecting the Cables

Once the antenna is properly installed, you can connect the antenna to the RoamAbout AP via the RoamAbout Lightning Protector.

1. Verify that the low-loss antenna cable is properly connected to the antenna cable.
2. Secure the low-loss cable to the mast such that the cable connectors do not support the full weight of the cable.
3. Provide a drip-loop at the bottom of the low-loss cable just before it enters the building.
4. Connect the opposite end of the low-loss cable to the RoamAbout Lightning Protector.



**Caution:** To avoid damage to the antenna cable and connectors, do not use tools to tighten cable connectors.

**Precaución:** para evitar daños en los cables y el conector de la antena, no use herramientas para apretar los conectores.

**Achtung:** Verwenden Sie kein Werkzeug zum Anziehen der Kabelanschlüsse. Durch Werkzeug können das Kabel und die Anschlüsse beschädigt werden.

5. Prior to securing the cable along its complete length, refer to “[Optimizing RoamAbout Outdoor Point-to-Point Antenna Placement](#)” on page 3-37. If required, adjust the direction of the antenna.
6. Once the installation has been fully tested, tighten antenna mounting nuts to lock the antenna into its position.



**Caution:** To prevent damage, avoid over-tightening the connectors, nuts, and screws used to mount the antenna.

**Precaución:** evite apretar demasiado los conectores, tuercas y tornillos usados para instalar la antena, para no dañarlos.

**Achtung:** Beugen Sie Schaden vor, indem Sie die Anschlüsse, Muttern und Schrauben für die Antenne nicht zu fest anziehen.

7. Secure the cable along its complete length. No part of the cable should be allowed to hang free.
8. Use waterproof stretch tape to seal all outdoor connectors.

## Optimizing RoamAbout Outdoor Point-to-Point Antenna Placement

If an AP is connected to an outdoor directional antenna, the antenna must be pointed directly at the antenna for the other AP. A misaligned antenna can decrease the signal level or prevent communications. Aligning an omni-directional antenna is less critical due to its wide radiation pattern. For optimal performance, make sure the antennas are properly aligned by using a pair of binoculars to point the antennas at each other.

### Routine Maintenance

Routine maintenance is required for each RoamAbout Lightning Protector in your outdoor antenna installation. Maintenance involves replacing the Lightning Protector at some interval depending on the lightning/transient discharge activity in your area.



**Note:** Contact a local antenna installation company to determine the maintenance schedule for each RoamAbout Lightning Protector in your outdoor antenna installation.





## Specifications

This appendix lists the specifications for the RoamAbout antennas.

For information about...	Refer to page...
<a href="#">RoamAbout 2.4 GHz 8 dBi Omni-Directional Base Station Antenna</a>	A-2
<a href="#">RoamAbout 2.4 GHz Directional Panel Antenna</a>	A-3
<a href="#">RoamAbout 2.4 GHz Sector Panel Antenna</a>	A-4
<a href="#">RoamAbout 2.4 GHz 6 dBi 180 Degree Sector Panel Antenna</a>	A-5
<a href="#">RoamAbout 2.4 GHz 7 dBi 120 Degree Sector Panel Antenna</a>	A-6
<a href="#">RoamAbout 2.4 GHz 10 dBi 60 Degree Sector Panel Antenna</a>	A-7
<a href="#">RoamAbout 5.1-5.9 GHz 10.8 dBi 180 Degree Sector Panel Antenna</a>	A-8
<a href="#">RoamAbout 5.1-5.9 GHz 12.5 dBi 120 Degree Sector Panel Antenna</a>	A-9
<a href="#">RoamAbout 5.1-5.9 GHz 14.5 dBi 60 Degree Sector Panel Antenna</a>	A-10
<a href="#">RoamAbout 5.3 GHz 10db Omni-Directional Antenna</a>	A-11
<a href="#">RoamAbout 5.8 GHz 10 dBi Omni-Directional Antenna</a>	A-12
<a href="#">RoamAbout 5.8 GHz Panel Antenna</a>	A-13
<a href="#">RoamAbout 4.9 to 5.9 GHz Sector Panel Antenna</a>	A-15
<a href="#">802.11a/b/g Range Extender Omni-Directional Antenna</a>	A-16
<a href="#">RoamAbout Pigtail Connection</a>	A-17
<a href="#">Low-Loss Antenna Cable</a>	A-18
<a href="#">RoamAbout Lightning Protector</a>	A-21

# RoamAbout 2.4 GHz 8 dBi Omni-Directional Base Station Antenna

Part number RBTES-BG-M08M.



**Notes:**

- This antenna is only supported with the RBT-4102, RBT-4102-EU, and the RBT-4102-BG. It cannot be used with the RBT-1602 or the RBT-1002.

**Table A-1 2.4 GHz Omni-Directional Antenna Specifications**

Specification	Value
<b>Electrical</b>	
• Frequency Range	2400–2483.5 MHz
• Gain	8 dBi
• Polarization	Vertical
• Nominal Impedance	50 Ohms
• Bandwidth at 1.5:1 WSWR	100 MHz
• Vertical Beamwidth at half power	13 degrees
• VSWR	Less than 1.5:1
• Maximum Power	25 Watts
<b>Mechanical</b>	
• Wind Survival	125 mph (201 km/h)
• Equivalent Flat Plate Area	.06 ft
• Lateral Thrust at Rated Wind	5.2 lb
• Bending Moment at Rated Wind	4.4 ft-lb
• Height	20.2 in. (513.1 mm)
• Weight	0.5 lb (0.226 kg)
<b>Mounting</b>	
• Method	Aluminum extruded mast mounting bracket
• Base Diameter	1.25 in. (31.75 mm)
<b>Termination</b>	Reverse-N Male



## RoamAbout 2.4 GHz Directional Panel Antenna

Part number RBTES-BG-P18M.



**Note:** This antenna can only be used in North America and Japan on the RBT-4102 and the RBT-4102-EU, respectively.

**Table A-2 RoamAbout 2.4 GHz Directional Panel Antenna Specifications**

Specification	Value
<b>Electrical</b>	
• Frequency Range	2300–2500 MHz
• Gain	18 dBi
• Front-to-Back Ratio	Greater than 25 dBi
• Polarization	Linear, vertical/horizontal
• Nominal Impedance	50 Ohms
• 3 dBi Horizontal Beamwidth	18 degrees
• 3 dBi Vertical Beamwidth	19 degrees
• VSWR	Less than 1.5:1
• Maximum Power	20 Watts
<b>Mechanical</b>	
• Wind Loading (Frontal) at 100 mph wind	85 lb (38.5 kg)
• Dimensions	15.1 in. x 13.9 in. x 1.9 in. (38.3 cm x 35.3 cm x 4.8 cm)
• Weight	3.9 lb (1.8 kg)
<b>Mounting</b>	Mast
<b>Termination</b>	Reverse-N Male

## RoamAbout 2.4 GHz Sector Panel Antenna

Part number RBTES-BG-S1490M.



**Note:** This antenna can only be used with the RBT-4102, RBT-4102 -EU, and the RBT-4102-BG.

**Table A-3 RoamAbout 2.4 GHz Directional Panel Antenna Specifications**

Specification	Value
<b>Electrical</b>	
• Frequency Range	2400–2485 MHz
• Gain (nominal)	14 dBi
• Front-to-Back Ratio	23 dBi
• Polarization	Vertical
• Nominal Impedance	50 Ohms
• Horizontal Plane Beamwidth	90 degrees
• E-plane Beamwidth	14 degrees
• VSWR	Less than 1.5:1
• Maximum Power	
<b>Mechanical</b>	
• Wind Survival	201 km/h (125 mph)
• Dimensions	50.3 cm L x 7.9 cm W x 3.81cm D (19.8 in. L x 3.1 in. W x 1.5 in. D)
• Weight	1.13 kg (2.5 lb)
<b>Mounting</b>	Mast
<b>Termination</b>	Reverse-N Male

## RoamAbout 2.4 GHz 6 dBi 180 Degree Sector Panel Antenna

Part number RBTES-BG-S06180.



**Note:** This antenna can only be used with the RBT-1602.

**Table A-4 RoamAbout 2.4 GHz 6 dBi Directional Panel Antenna Specifications**

Specification	Value
<b>Electrical</b>	
• Frequency Range	2400–2483 MHz
• Gain (nominal)	≥ 6 dBi
• Front-to-Back Ratio	≥ 6 dBi
• Polarization	Vertical, Linear
• Nominal Impedance	50 Ohms
• 3 dB Horizontal Beamwidth	180 degrees
• 3 dB Vertical Beamwidth	40 degrees
• VSWR	≤ 1.5:1 (or ≥ 14 dB)
• Maximum Power	20 W
<b>Environmental</b>	
• Temperature Range	-45 °C to +75 °C (-49 °F to 167 °F)
• Storage Temperature	-30 °C to +75 °C (22 °F to 167 °F)
<b>Mechanical</b>	
• Wind Loading (frontal)	≥ 7 (200 km/h)
• Dimensions	52 mm W x 198 mm L x 30 cm D (2.05 in. W x 7.99 in. L x 1.18 in.D)
• Weight	0.5 lb
• Radome Material	ASA with UV protection
• Connector	Reverse-N Male
<b>Mounting</b>	Wall mount, pole mount

# RoamAbout 2.4 GHz 7 dBi 120 Degree Sector Panel Antenna

Part number RBTES-BG-S07120.



**Note:** This antenna can only be used with the RBT-1602.

**Table A-5 RoamAbout 2.4 GHz 7 dBi Directional Panel Antenna Specifications**

Specification	Value
<b>Electrical</b>	
• Frequency Range	2400–2483 MHz
• Gain (nominal)	≥ 7dBi
• Front-to-Back Ratio	≥ 14 dBi
• Polarization	Vertical, Linear
• Nominal Impedance	50 Ohms
• 3 dB Horizontal Beamwidth	120 degrees
• 3 dB Vertical Beamwidth	60 degrees
• VSWR	≤ 1.5:1 (or ≥ 14 dB)
• Maximum Power	20 W
<b>Environmental</b>	
• Temperature Range	-45 °C to +75 °C (-49 °F to 167 °F)
• Storage Temperature	-30 °C to 75 °C (22 °F to 167 °F)
<b>Mechanical</b>	
• Wind Loading (frontal)	≥ 10 Kg (125 km/h)
• Dimensions	52 mm W x 113 mm L x 30cm D (2.04 in. W x 4.45 in. L x 1.18 in.D)
• Weight	0.5 lb
• Radome Material	ASA with UV protection
• Connector	Reverse-N Male
<b>Mounting</b>	Wall mount, pole mount

## RoamAbout 2.4 GHz 10 dBi 60 Degree Sector Panel Antenna

Part number RBTES-BG-S1060.



**Note:** This antenna can only be used with the RBT-1602.

**Table A-6 RoamAbout 2.4 GHz 10 dBi Directional Panel Antenna Specifications**

Specification	Value
<b>Electrical</b>	
• Frequency Range	2400–2483 MHz
• Gain (nominal)	> 10 dBi
• Front-to-Back Ratio	> 20 dBi
• Polarization	Vertical, Linear
• Nominal Impedance	50 Ohms
• 3 dB Horizontal Beamwidth	60 degrees
• 3 dB Vertical Beamwidth	65 degrees
• VSWR	≤ 1.5:1 (or ≥ 14 dB)
• Maximum Power	20 W
<b>Environmental</b>	
• Temperature Range	-45 °C to +75 °C (-49 °F to 167 °F)
• Storage Temperature	-30 °C to +75 °C (22 °F to 167 °F)
<b>Mechanical</b>	
• Wind Loading (frontal)	≥ 10 Kg (125 km/h)
• Dimensions	1.143 mm W x 111.7 mm L x 25.4 cm D (4.5 in. W x 4.4 in. L x 1 in.D)
• Weight	0.5 lb
• Lightning Protection	Direct grounding
• Radome Material	ASA with UV protection
• Connector	Reverse-N Male
<b>Mounting</b>	Wall mount, pole mount

# RoamAbout 5.1-5.9 GHz 10.8 dBi 180 Degree Sector Panel Antenna

Part number RBTES-AW-S10180



**Note:** This antenna can only be used with the RBT-1602.

**Table A-7 RoamAbout 5.1-5.9 GHz 10.8 dBi Sector Panel Antenna Specifications**

Specification	Value
<b>Electrical</b>	
• Frequency Range	5100 - 5900 MHz
• Gain (nominal)	10.8 dBi
• Front-to-Back Ratio	> 19 dBi
• Polarization	Vertical, Linear
• Nominal Impedance	50 Ohms
• 3 dB Horizontal Beamwidth	180 degrees
• 3 dB Vertical Beamwidth	14 degrees
• VSWR	≤ 1.5:1 (or ≥ 14 dB)
• Maximum Power	20 W
<b>Environmental</b>	
• Temperature Range	-45 °C to +75 °C (-49 °F to 167 °F)
• Storage Temperature	-30 °C to +75 °C (22 °F to 167 °F)
<b>Mechanical</b>	
• Wind Loading (frontal)	≥ 5 Kg (200 km/h)
• Dimensions	317.5 mm W x 50.8 mm L x 50.8 cm D (12.5 in. W x 2 in. L x 2 in.D)
• Weight	170 g (0.375 lb)
• Radome Material	ASA with UV protection
• Connector	Reverse-N Male
<b>Mounting</b>	Wall mount, pole mount

# RoamAbout 5.1-5.9 GHz 12.5 dBi 120 Degree Sector Panel Antenna

Part number RBTES-AW-S12120.



**Note:** This antenna can only be used with the RBT-1602.

**Table A-8 RoamAbout 5.1-5.9 GHz 12.5 dBi Sector Panel Antenna Specifications**

Specification	Value
<b>Electrical</b>	
• Frequency Range	5100 - 5900 MHz
• Gain (nominal)	12.5 dBi
• Front-to-Back Ratio	> 28 dBi
• Polarization	Vertical, Linear
• Nominal Impedance	50 Ohms
• 3 dB Horizontal Beamwidth	120 degrees
• 3 dB Vertical Beamwidth	14 degrees
• VSWR	≤ 1.5:1 (or ≥ 14 dB)
• Maximum Power	20 W
<b>Environmental</b>	
• Temperature Range	-45 °C to +75 °C (-49 °F to 167 °F)
• Storage Temperature	-30 °C to +75 °C (22 °F to 167 °F)
<b>Mechanical</b>	
• Wind Loading (frontal)	≥ 5 Kg (200 km/h)
• Dimensions	317.5 mm W x 68.58 mm L x 50.8 cm D (12.5 in. W x 2.7 in. L x 2 in.D)
• Weight	170 g (0.375 lb)
• Radome Material	ASA with UV protection
• Connector	Reverse-N Male
<b>Mounting</b>	Wall mount, pole mount

# RoamAbout 5.1-5.9 GHz 14.5 dBi 60 Degree Sector Panel Antenna

Part number RBTES-AW-S1460.



**Note:** This antenna can only be used with the RBT-1602.

**Table A-9 RoamAbout 5.1-5.9 GHz 14.5 dBi Sector Panel Antenna Specifications**

Specification	Value
<b>Electrical</b>	
• Frequency Range	5100 - 5900 MHz
• Gain (nominal)	14.5 dBi
• Front-to-Back Ratio	> 25 dBi
• Polarization	Vertical, Linear
• Nominal Impedance	50 Ohms
• 3 dB Horizontal Beamwidth	60 degrees
• 3 dB Vertical Beamwidth	14 degrees
• VSWR	≤ 1.5:1 (or ≥ 14 dB)
• Maximum Power	20 W
<b>Environmental</b>	
• Temperature Range	-45 °C to +75 °C (-49 °F to 167 °F)
• Storage Temperature	-30 °C to +75 °C (22 °F to 167 °F)
<b>Mechanical</b>	
• Wind Loading (frontal)	≥ 10 Kg (200 km/h)
• Lightning Protection	Direct Grounding
• Dimensions	63.5 mm W x309.9 mm L x 24.5 cm D (2.5 in. W x 12.2 in. L x 1 in.D)
• Weight	100 g (0.220 lb)
• Radome Material	ASA with UV protection
• Connector	Reverse-N Male
<b>Mounting</b>	Wall mount, pole mount



## RoamAbout 5.3 GHz 10db Omni-Directional Antenna

Part number RBTES-AM-M10M.



**Note:** This antenna can only be used with the RBT-4102, and the RBT-4102-EU.

**Table A-10 5.3 GHz Omni-Directional Antenna Specifications**

Specification	Value
<b>Electrical</b>	
• Frequency Range	5.15–5.35 GHz
• Gain Omni cut plane gain measurement over the frequency band	10 dBi +/- 1 dBi
• Polarization	Vertical
• Nominal Impedance	50 Ohms
• Undulation Ratio in the Horizontal Plane	2.4 dBi (Type)
• -3 dBi Beamwidth in the Vertical Plane	8.5 degrees +/- 0.5 degrees
• Cross Polarization Level in Horizontal and Vertical Planes	Greater than 24 dBi
• VSWR	1.5 Max (Normal and icing conditions)
• Maximum Power	20 Watts
<b>Mechanical</b>	
• Wind-loading (in accordance with the ETS 300 019-1-4.4.1E)	139.00 km/h (86.4 mph)
• Height	429 mm (16.8 in.)
• Weight	139.000 g (.306 lb)
<b>Mounting</b>	Mast or wall mounting
<b>Termination</b>	Reverse-N Male
<b>Environmental</b>	
Temperature	
• Stationary	-40 to +55 °C (-40 to 131 °F)
• Cyclic	-40 to +55 °C (-40 to 131 °F) Rate 0.5 °C/minute
• Humidity (Stationary)	93% @ 30 °C (86 °F)
• Vibration (Sinusoidal)	+/- 3 mm / 10 m/s <sup>2</sup>
• Shocks	250 m/s <sup>2</sup>

## RoamAbout 5.8 GHz 10 dBi Omni-Directional Antenna

Part number RBTES-AH-M10M.



**Note:** This antenna can only be used with the RBT-4102, and the RBT-4102-LIC, in North America.

**Table A-11 5.8 GHz Omni-Directional Antenna Specifications**

Specification	Value
<b>Electrical</b>	
• Frequency Range	5.725–5.875 GHz
• Gain Omni cut plane gain measurement over the frequency band	10 dBi +/- 1 dBi
• Polarization	Vertical
• Nominal Impedance	50 Ohms
• Undulation Ratio in the Horizontal Plane	2.4 dBi (Typ)
• -3 dBi Beamwidth in the Vertical Plane	8.5 degrees +/- 0.5 degrees
• Cross Polarization Level in Horizontal and Vertical Planes	Greater than 23 dBi
• VSWR	1.5 Max (Normal and icing conditions)
• Maximum Power	20 Watts
<b>Mechanical</b>	
• Wind-loading (in accordance with the Enterasys 300 019-1-4.4.1E)	200.00 km/h (125 mph)
• Height	394 mm (15.5 in.)
• Weight	134.000 g (.295 lb)
<b>Mounting</b>	Mast or wall mounting
<b>Termination</b>	Reverse-N Male
<b>Environmental</b>	
<b>Temperature</b>	
• Stationary	-40 to +55 °C (-40 to 131 °F)
• Cyclic	-40 to +55 °C (-40 to 131 °F) Rate 0.5 °C/minute
• Humidity (Stationary)	93% @ 30 °C (86 °F)
• Vibration (Sinusoidal)	+/- 3 mm / 10 m/s <sup>2</sup>
• Shocks	250 m/s <sup>2</sup>

## RoamAbout 5.8 GHz Panel Antenna

Part number RBTES-AH-P23M.



**Note:** This antenna can only be used with the RBT-4102, and the RBT-4102-LIC, in North America.

**Table A-12 RoamAbout 5.8 GHz Panel Antenna Specifications**

Specification	Value
<b>Electrical</b>	
• Frequency Range	5.725–5.825 GHz
• Front-to-Back Ratio	-30 dBi maximum
• Gain (overall)	21.7 dBi (Typ)
• Gain (radiating element)	22.5 dBi (Typ)
• Polarization	Vertical
• Nominal Impedance	50 Ohms
• -3 dBi Horizontal Beamwidth	11.7 degrees
• -3 dBi Vertical Beamwidth	14.5 degrees
• Side Lobe Level	
Angle: 0 - 90 degrees	Less than -15 dBi
Angle: 90 - 120 degrees	Less than -20 dBi
Angle: 120 - 180 degrees	Less than -30 dBi
• Cross Polarization Level - Horizontal Plane	-17 dBi maximum
• VSWR	Less than 1.5 maximum
• Maximum Power	20 Watts
<b>Mechanical</b>	
• Wind Load at 100 MPH	
Front	44.5 (198) lb (N) maximum
Twisting Moment M	2.15 (2.9) lb ft (N.m)
• Azimuth adjustment	+/- 40 degrees +/- 4 degrees
• Elevation adjustment	+/- 40 degrees +/- 4 degrees
• Dimensions	12.1 in. x 12.1 in. x 1.4 in. (308 mm x 308 mm x 35 mm)
• Weight	5.6 lb (2.55 kg)
<b>Mounting</b>	Mast and wall
<b>Termination</b>	Reverse-N Male

**Table A-12 RoamAbout 5.8 GHz Panel Antenna Specifications (continued)**

Specification	Value
<b>Environmental</b>	
Temperature:	
• Operating	-40 to +70 °C (-40 to +158 °F)
• Stationary	-45 to +60 °C (-49 to 140 °F)
• Cyclic	-45/+60 °C (-49 to 140 °F) Rate 0.5 °C/minute
Humidity	
• Stationary	93% @ 30 °C (86 °F)
• Cyclic	90% @ 30 °C (86 °F)
Vibration	
• Sinusoidal	+/- 5 mm / 2 m/s <sup>2</sup>
• Random	0.03 g <sup>2</sup> Hz
Shocks	250 m/s <sup>2</sup>

## RoamAbout 4.9 to 5.9 GHz Sector Panel Antenna

Part number RBTES-AW-S1590M.



**Note:** This antenna can only be used with the RBT-4102, RBT-4102-EU, and the RBT-4102-LIC.

**Table A-13 RoamAbout 4.9 to 5.9 GHz Sector Panel Antenna Specifications**

Specification	Value
<b>Electrical</b>	
• Frequency Range	4.9 to 6.0 GHz
• Gain (nominal)	16 dBi at 60 degrees (with baffle attached) 15 dBi at 90 degrees
• Front-to-Back Ratio	32 dBi
• Polarization	Horizontal
• Nominal Impedance	Not available
• Horizontal Plane Beamwidth	60 or 90 degrees (adjustable)
• E-plane Beamwidth	8 degrees
• Typical Cross Poll Discrimination	Greater than 20 dBi
• VSWR	Less than 1.7:1
• Maximum Power	10 Watts
<b>Mechanical</b>	
• Rated Wind Velocity	125 mph (201 km/h)
• Lateral Thrust at Rated Wind	60 lbf without flaps 120 lbf with flaps
• Equivalent Flat Plane Area	.44 ft <sup>2</sup> without flaps 1.36 ft <sup>2</sup> with flaps
• Dimensions	24 in. L x 6 in. W x 3 in. D (60.96 cm L x 15.24 cm W x 7.62 cm D)
• Weight	4.5 lb (2.55 kg)
<b>Mounting</b>	Mast
<b>Termination</b>	Reverse-N Male
<b>Environmental</b>	
• Temperature	-30 °C to 75 °C (-22 °F to 167°F)

## 802.11a/b/g Range Extender Omni-Directional Antenna

Part number RBT4K-AG-IA.



**Note:** This antenna can only be used with the RBT-4102, RBT-4102-EU, RBT-4102-BG, and the RBT-4102-LIC.

**Table A-14 802.11a/b/g Range Extender Omni-Directional Antenna Specifications**

Specification	Value
Weight	85 gram (0.187 lb)
Frequency Range	<ul style="list-style-type: none"> <li>• 2.4: 2.4 to 2.5 GHz</li> <li>• 5.2—5.8: 4.9 to 5.9 GHz</li> </ul>
Gain (@ ± 30° /Horizontal) (Gain is including cable losses)	0 dBi +/-1 dB 2 dBi @ 5 GHz
Polarization	Vertical
Nominal Impedance	50 Ohms
VSWR	2 typical
Power withstanding	20 Watts
Radiation Pattern	<ul style="list-style-type: none"> <li>• Horizontal Plane: Omni-directional Ripple: 2 dB Cross Polarization: -15 dB</li> <li>• Vertical Plane: Dipolar type -3 dB beamwidth: 54 °(Typ) Cross Polarization: -15 dB</li> </ul>
Mounting	Ceiling
Termination	Reverse SMA Female, with an attached eight foot cable
Operating Temperature	-45 °C to +90 °C (-49 °F to 194 °F)

## RoamAbout Pigtail Connection

Part Number: RBT4K-AG-PT20F or RBT4K-AG-PT20M. One end is a Reverse SMA connector, and the other end is Reverse-N female or male, respectively.

The end with the Reverse SMA connector connects to the RBT-1602 and the RBT-4102. The Reverse-N connector at the opposite end of the cable matches the polarity of the Reverse-N connectors of the other components that are part of your outdoor antenna cabling system.

**Table A-15 Pigtail Connection Specification**

Specification	Value
<b>Mechanical</b>	
• Length	20 in. (50.8 cm)
• Weight	0.0092 lb/ft (0.014 kg/m)
• Bend Radius	0.25 in. (6.4 mm)
• Tensile Strength	15 lb (6.8 kg)
<b>Environmental</b>	
• Temperature Range:	
- Operating	-40 to +85 °C (-40 to +185 °F)
- Storage	-70 to +85 °C (-94 to +185 °F)
<b>Electrical</b>	
• Cutoff Frequency	90 GHz
• Velocity of Propagation	66%
• Shielding Effectiveness	Greater than 90 dBi
• DC Resistance	
- Inner Conductor	81.0 ohms/1000ft (266 ohms/km)
- Outer Conductor	9.5 ohms/1000ft (31.2 ohms/km)
• Peak Power	0.6 kW
<b>Connector Type</b>	Reverse SMA Connector Reverse-N, Female or Male
<b>Cable Loss</b>	2.4 GHz: 0.65 dB 5.3 GHz: 1.0 dB 5.8 GHz: 1.1 dB

## Low-Loss Antenna Cable

The RoamAbout low-loss, outdoor, watertight cable is available in the following standard lengths:

- 20 feet (6.1 meters) (RBTES-L200-C20F) - refer to [Table A-16](#).
- 25 feet (7.6 meters) (RBTES-L400-C25F) - refer to [Table A-17](#).
- 50 feet (15.24 meters) (RBTES-L400-C50F) - refer to [Table A-17](#).
- 50 feet (15.24 meters) (RBTES-L600-C50F) - refer to [Table A-18](#).
- 75 feet (22 meters) (RBTES-L400-C75F) - refer to [Table A-17](#).

To ensure you order the right cable length, carefully determine the distance between the locations where you intend to mount the RoamAbout AP and outdoor antenna.

**Table A-16 RBTES-L200 Cable Specification**

Specification	Value
<b>Mechanical</b>	
• Length	6.1 meter (20 ft)
• Weight	0.002 lb/ft (0.03 kg/m)
• Bend Radius	0.5 in. (12.7mm)
• Tensile Strength	40 lb (18.2 kg)
<b>Environmental</b>	
• Temperature Range:	
- Operating	-40 to +85 °C (-40 to +185 °F)
- Storage	-70 to +85 °C (-94 to +185 °F)
<b>Electrical</b>	
• Cutoff Frequency	39 GHz
• Velocity of Propagation	83%
• Shielding Effectiveness	Greater than 90 dBi
• DC Resistance	
- Inner Conductor	5.36 ohms/1000ft (17.6 ohms/km)
- Outer Conductor	4.9 ohms/1000ft (16.1 ohms/km)
• Peak Power	2.5 kW
<b>Connector Type</b>	Reverse-N (Female on both ends)
<b>Cable Loss</b>	2.4 GHz: 3.3 dB
	5.3 GHz: 5 dB
	5.8 GHz: 5.3 dB



**Table A-17 RBTES-L400 Cable Specifications**

<b>Specification</b>	<b>Value</b>
<b>Mechanical</b>	
• Length	50 ft (15.24 m) 75 ft (22.9 m)
• Weight	0.068 lb/ft (0.10 kg/m)
• Bend Radius	1.00 in. (25.4 mm)
• Tensile Strength	160 lb (72.6 kg)
<b>Environmental</b>	
• Temperature Range:	
- Operating	-40 to +85 °C (-40 to +185 °F)
- Storage	-70 to +85 °C (-94 to +185 °F)
<b>Electrical</b>	
• Cutoff Frequency	16.2 GHz
• Velocity of Propagation	85%
• Shielding Effectiveness	Greater than 90 dBi
• DC Resistance	
- Inner Conductor	1.39 ohms/1000ft (4.6 ohms/km)
- Outer Conductor	1.65 ohms/1000ft (5.4 ohms/km)
• Peak Power	16 kW
<b>Connector Type</b>	Reverse-N (Female on both ends)
<b>Cable Loss</b>	<b>50 feet:</b>
	• 2.4 GHz: 3.3 dB
	• 5.3 GHz: 5.2 dB
	• 5.8 GHz: 5.4 dB
	<b>75 feet:</b>
	• 2.4 GHz: 5 dB
	• 5.3 GHz: 7.7 dB
	• 5.8 GHz: 8.1 dB

**Table A-18 RBTES-L600 Cable Specifications**

Specification	Value
<b>Mechanical</b>	
• Length	25 ft (7.6 m) 50 ft (15.24 m)
• Weight	0.131 lb/ft (0.20 kg/m)
• Bend Radius	1.50 in. (38.1 mm)
• Tensile Strength	350 lb (158.9 kg)
<b>Environmental</b>	
• Temperature Range:	
- Operating	-40 to +85 °C (-40 to +185 °F)
- Storage	-70 to +85 °C (94 to +185 °F)
<b>Electrical</b>	
• Cutoff Frequency	10.3 GHz
• Velocity of Propagation	87%
• Shielding Effectiveness	Greater than 90 dBi
• DC Resistance	
- Inner Conductor	0.53ohms/1000ft (1.7 ohms/km)
- Outer Conductor	1.2 ohms/1000ft (3.9 ohms/km)
• Peak Power	40 kW
<b>Connector Type</b>	Reverse-N (Female on both ends)
<b>Cable Loss</b>	<b>25 feet:</b>
	• 2.4 GHz: 1.1 dB
	• 5.3 GHz: 1.7 dB
	• 5.8 GHz: 1.8 dB
	<b>50 feet:</b>
	• 2.4 GHz: 2.2 dB
	• 5.3 GHz: 3.5 dB
	• 5.8 GHz: 3.6 dB

## RoamAbout Lightning Protector

Part number: RBTES-AG-LP.

The RoamAbout Lightning Protector is a surge arrester that protects your sensitive RoamAbout equipment from high-voltage currents caused by discharge and transients at the antennas.

[Table A-19](#) lists the specifications for the RoamAbout Lightning Protector.

**Table A-19 Lightning Protector Specifications**

Specification	Value
<b>Mechanical</b>	
• Height	2.7 in. (69 mm)
• Dimension	1 in. (26 mm)
• Weight	4.7 oz (133 g)
<b>Environmental</b>	
• Temperature Range (Operating and Storage)	-40 to +85 °C (-40 to +185 °F)
<b>Electrical</b>	
• Frequency Range	2.0 GHz to 6.0 GHz
• Return Loss	> 20 dB
• Insertion Loss	≤0.1 dB typical (≤0.2 dB maximum)
• Surge	10 kA IEC 1000–4–5 8/20 waveform
• VSWR	≤ 1.2 to 1 typical (≤ 1.3 to 1 maximum)
• Continuous Power	10 W
• Let Through Voltage	≤±3 Volts for 3 kA @ 8/20 waveform
• Throughput Energy	≤0.5 for 3 kA @ 8/20 waveform
• Vibration	1 G at 5 Hz to 100 Hz
<b>Connector Type</b>	Reverse-N (Female on both ends)

